



# FIELD TECHNICIAN CERTIFICATION WORKBOOK

**This material is copyrighted and all rights reserved. No portion of this material may be used in any form without written permission of Arizona Technical Testing Institute**

**ARIZONA TECHNICAL TESTING INSTITUTE**

**Revised AUGUST 2024**



**FORWARD:**

The Arizona Technical Testing Institute (ATTI) is a nonprofit organization formed to promote the highest standard in highway construction materials sampling and testing through certification of technicians. ATTI certifications emphasize a hands-on approach, that is, applicants must satisfactorily demonstrate test methods as well as pass a written exam to receive certification. The organization is represented by members from the Arizona Department of Transportation (ADOT), highway contractors, materials suppliers, materials testing laboratories, Arizona Rock Products Association (ARPA), Federal Highway Administration (FHWA), and Arizona General Contractors (AGC). ATTI certifications satisfy ADOT and federal requirements which specify that technicians performing materials sampling and testing on ADOT projects are properly qualified.

**ATTI provides the following certifications:**

**ATTI FIELD TECHNICIAN – field sampling and testing of soils, aggregates, asphalt, and asphaltic concrete,**

**ATTI LABORATORY SOILS/AGGREGATE TECHNICIAN – laboratory sampling and testing of soils and aggregate,**

**ATTI ASPHALT TECHNICIAN – laboratory sampling and testing of asphaltic concrete.**







## TABLE OF CONTENTS

- INTRODUCTION ..... i
- PERFORMANCE EXAMINATION..... i
- WRITTEN EXAMINATION .....ii
- RETESTING ..... ii
- CERTIFICATION ..... iii
- CANCELATION/NO SHOW ..... iii
- APPEALS ..... iii
- SAFETY ..... iv
- OSHA ..... iv
- PLAN & PROFILE ..... v
- PLAN DETAILS ..... v
- PROFILE DETAILS ..... v
- TYPICAL SECTIONS ..... vi
- REPRESENTATIVE SAMPLES ..... vi
- RANDOM SAMPLING ..... vi
- SAMPLING & TESTING RECORDS ..... x
- SAMPLE TICKETS ..... x
- TEST RESULTS ..... x
- MATERIALS PROPERTIES .....xi
- ENGINEERING PROPERTIES OF SOILS ..... xi
- ENGINEERING PROPERTIES OF AGGREGATES ..... xiii
- ENGINEERING PROPERTIES OF ASPHALTIC CONCRETE ..... xiii
- COMPACTION ..... xiv





## PROCEDURES



- **AASHTO R90: SAMPLING AGGREGATE PRODUCTS** ..... 2
- **AASHTO R97: SAMPLING ASPHALT MIXTURES**..... 8
- **AASHTO R66: SAMPLING ASPHALT MATERIALS**..... 15
- **AASHTO R76: REDUCING SAMPLES OF AGGREGATE TO TESTING SIZE**..... 21
- **AASHTO R67: SAMPLING ASPHALT MIXTURES AFTER COMPACTION (CORES)**.....29
  
- **AASHTO T191: DENSITY OF SOIL IN-PLACE BY THE SAND CONE METHOD**..... 34
- **AASHTO T217: MOISTURE CONTENT BY CALCIUM CARBIDE METHOD**..... 39
- **AASHTO T272: ONE-POINT METHOD FOR DETERMINING MAXIMUM DRY DENSITY & OPTIMUM MOISTURE** .....42
- **ANNEX T99: CORRECTION FOR MAX. DRY DENSITY & OPTIMUM MOISTURE CONTENT FOR OVERSIZED PARTICLES**.....53
- **AASHTO T19 SECTION 8: CALIBRATION OF MEASURE**.....56
- **AASHTO T310: IN PLACE DENSITY AND MOISTURE CONTENT OF SOIL – AGGREGATE BY NUCLEAR METHODS**..... 60
- **AASHTO T355: DENSITY OF COMPACTED BITUMINOUS MIXTURES BY NUCLEAR METHOD**..... 64
- **AASHTO T265: MOISTURE CONTENT OF SOILS**.....69
- **AASHTO T255: MOISTURE CONTENT OF AGGREGATES**..... 71

## **INTRODUCTION:**



-  The ATTI Field Technician Certification program evaluates the competency of applicants performing sampling and testing of soils, aggregates, bituminous materials, and hot mix in the field.
-  Certification is based on satisfactory demonstration of all specified sampling and testing methods, as well as passing a written examination. Applicants are advised to receive training or have experience performing the test methods and calculations before attempting to obtain certification.
-  This workbook provides information regarding the requirements for ATTI Field Technician certification, administration of the certification process, and topics covered during the certification, administration of the certification process, and topics covered during the certification examinations.
-  Brief coverage is given to safety issues, plan and profile, representative samples, record keeping, and properties of soils, aggregates, and asphaltic hot mix. Most importantly, the workbook contains copies of the applicable testing methods which a certified ATTI Field Technician must be able to perform.

## **PERFORMANCE EXAMINATION:**



-  As Stated earlier, the emphasis of this certification program is technician demonstration of proficiency in performing all test methods which have been specified above.
-  Technicians may not use any notes or books while taking the performance exam. The examiner will maintain possession of all examination paperwork.
-  Instead of performing both Method A and Alternate Method D one point proctor tests, the examiner may ask the technician to verbally recite the differences between the two tests.
-  The examiner will use standardized checklists to verify proper procedure by the technician. During the performance examination, the examiner will indicate a technician's compliance with each identified item on the individual test method checklist with a "Yes" or "No" in the space provided. If any significant deficiencies are observed during the exam, the examiner must indicate "No" for that item. Any "No" will constitute failure of that test method. All checklist items must be performed correctly or the test method is considered failed.
-  Once completed, the examiner will inform the technician if the test method was passed or failed. If failed, the examiner will indicate the step or steps that were not performed properly. The failed test method may be demonstrated a second time at the discretion of the examiners. The retest should be performed after all other tests have been completed, the technician has studied the failed test method, and the examiner is available. If a test method is failed a second time, the applicant must schedule a retest within 1 year at a cost of \$50.00.

-  If the technician requests to start over a test method once they have begun, the examiner will allow the technician to restart the test method and disregard findings of the incomplete test. The technician will be allowed to restart a test method one time only.
  
-  If the technician has successfully attained an ATII Asphalt, Soils I Aggregate, or Field Technician Certification within the last 12 months you may receive credit for some of the test methods performed included in that certification.
  
-  ***It is recommended that technicians perform all test methods during an examination period. Any test methods not performed will be considered failed.***

### **WRITTEN EXAMINATION:**

-  The written examination has a 3-hour time limit to complete. The questions and calculations are derived directly from the previously mentioned test methods and from information presented in the first few chapters of this manual. Eighty (80) percent of the written examination questions must be answered correctly and all calculations performed correctly to achieve a passing score.
  
-  Notes and books may not be used while taking the written examination. The examiner will maintain possession of all examination paperwork.

### **RETEST:**

-  If a technician fails to successfully demonstrate a test method as prescribed, the technician may be allowed to demonstrate the failed test method a second time during the same examination period at the discretion of the examiners. The retest should be performed after all other tests have been completed, the technician has studied the failed test method, and the examiner is available. Failed test methods must be re-demonstrated within twelve months of the original examination date. All retesting is at the discretion of the examiners.
  
-  A technician failing the written or calculations examination is required to retake the entire written or calculations examination within twelve months of the original test date.
  
-  If a technician fails the performance and /or written examinations a second time, a fee will be charged for additional testing that must be performed within twelve months of the original examination date. If the failed items are not successfully passed the third try, the technician will be required to register and retake the entire certification examination.





### **CERTIFICATION:**

-  To receive certification, the technician must successfully demonstrate all test methods as well as correctly answer at least 80 percent of the written exam questions and correctly perform all calculations. Certification is granted for a period of five years. Successful completion of the entire examination program is required for re-certification.

### **CANCELLATION / NO SHOW POLICY:**

-  The cancellation policy is detailed in the ATTI Administration Manual which is available on the ATTI website at [www.attiaz.org](http://www.attiaz.org).

### **APPEALS:**

-  ATTI certification examinations, policies, procedures, requirements, and materials are developed through a cooperative effort of the ATTI technical advisory board and industry experts. The ATTI Board of Directors approves and provides oversight of the certification program. If a technician feels that the certification exams have not been correctly administered or if the technician desires to appeal their exam scores, they may do so.
-  Appeals should be made in the following sequence:
  1. Senior Examiner
  2. Executive Director
  3. Technical Advisory Board
  4. ATTI Board of Directors
-  If there is not consensual resolution at any level, the technician may escalate their appeal to the next level. The decision of the Board of directors is final.
-  Technicians are encouraged to provide feedback to ATTI on any portion of the examinations, manual content, exam administration, or requirements of the ATTI certification process. The comments received will be discussed by the technical advisory board and, if merited, revisions to the program will be initiated.

### **SAFETY:**

- Some of the test methods in this manual may involve hazardous materials operations, and/or equipment. This manual does not claim to address all relevant safety issues which may be encountered or which may be associated with its use or with the performance of test procedures introduced here.
- It is the responsibility of the technician to determine, establish, and follow appropriate health and safety practices. The technician must also determine the applicability of any regulatory limitations of test equipment and chemicals.

### **OSHA:**

- OSHA has established safety requirements for individuals working in various environments. In the field and laboratory these requirements include such measures as wearing hard hats, eye protection, and protective footwear as well as the need to observe certain precautions when operating machinery and other equipment.
- There are also regulations pertaining to the handling and storage of chemicals, nuclear devices, and other hazardous materials. This short discussion on safety is not meant to preclude or to include OSHA requirements. It is up to the individual technician to be acquainted with OSHA regulations that apply to their particular job assignment.



## PLAN & PROFILE

- 🌱 The plan and profile of a specific segment of a roadway are typically printed on a single sheet of the project plans with the plan view at the top of the sheet and the corresponding profile view at the bottom of the sheet. Plan and profiles are drawn such that profile stationing is directly below the plan stationing. See Figure 1.
- 🌱 The plan shows an aerial view of the roadway, as if the observer is looking directly down on the roadway. Roadway details such as horizontal alignment, roadway width, right-of-way, and structure locations are illustrated on the plan sheet relative to the roadway centerline. The profile shows a longitudinal cross-section view of the roadway elevation, taken through the centerline of the roadway. The profile illustrates details such as vertical alignment of the centerline, existing ground line elevation, culvert elevation, and structure elevations.

### **PLAN DETAILS**

- 🌱 The **centerline**, denoted,  $\mathcal{C}$ , the surveyed center of the roadway. It may be an existing centerline or a newly established centerline. If both are illustrated, they should be clearly identified.
- 🌱 **Station numbers** are established along the centerline. Each station represents 100 feet; therefore, a distance of 700 feet is equivalent to 7 stations. Most projects will begin at station 0+00 and increase in stationing to the end of the project. For example, the location of a culvert is given as Station 21+76.8 which is equal to 2,176.8 feet from the beginning of the project. When a new centerline is established, and it is desired that the new stationing matches the old, it is often necessary to add a correction equation.
- 🌱 Sampling of roadway materials is conducted randomly; consequently, very few samples are taken on the centerline. Specific sample locations are identified by station and **centerline offset** to the left of centerline or to the right of centerline. As an individual is facing in the direction of increasing stationing, the individual's left defines "left of centerline" and the individual's right defines "right of centerline."

### **PROFILE DETAILS**

- 🌱 **Elevations** of various roadway centerline details are illustrated on the profile sheet. The elevations represent vertical distance above or below sea level.
- 🌱 The existing ground elevation along the **centerline** and the design finished roadway **centerline** are illustrated by lines drawn at the appropriate elevations.
- 🌱 The top elevation and depth of a sample is often drawn on the profile sheet.

## **TYPICAL SECTIONS**

- 🌱 **Typical sections** illustrate the components and dimensional requirements of each pavement structure used on the project. The typical pavement sections are cross-sections taken transversely across the roadway. See Figure 2.
- 🌱 **Pavement structural sections** provide details on the material type and depth of each layer of the pavement structure. The pavement structure includes all pavement materials placed above the subgrade, including aggregate subbase, aggregate base, asphaltic concrete, Portland cement concrete, and asphaltic concrete friction course.

## **REPRESENTATIVE SAMPLES**

- 🌱 As should be apparent, acceptance or rejection of materials is highly dependent on the representativeness of a small sample that is tested to determine the quality of a large quantity of material. If the sample is not truly representative of the larger quantity, acceptable material might be rejected or unacceptable material might be accepted. Unbiased samples must be obtained in a way that the true nature of the material is represented. For example, aggregate stockpiles should not be sampled at the surface where coarser slough material is present. Similarly, all material from an asphaltic concrete plate sample should be obtained with single strokes of the sampling device through the middle of the plate, excluding material that sloughs onto the plate after initial sampling.

## **RANDOM SAMPLING**

- 🌱 A random sample is any sample which has an equal chance as any other sample of being selected from a population. In other words, there is an equal chance for all locations and all fractions of materials to be sampled.
- 🌱 Samples should not be obtained on a predetermined basis or based on the quality of the material in a certain area. If sampling is not performed on a random basis, the quality of the sample can be artificially modified and the sample will no longer be representative of the larger quantity.
- 🌱 When a sample is not representative, it is said to be biased. Examples of biased sampling that should not be used include sampling a roadway at a given interval such as 1500 feet; sampling asphaltic concrete production at a given frequency, such as every 500 tons; or taking samples at a given time, such as every hour on the hour.
- 🌱 Random sampling is usually accomplished with the use of random number generators or tables of random numbers. Most calculators and computers contain a random number generator that merely requires the operator to hit a button. The automated random number generators use programmed tables of random numbers similar to the table shown in figure 3. Random number tables are simply random arrangements of numbers of any table length.

.72	.51	.98	.45	.01	.55	.25	.24	.73	.43
.99	.13	.69	.59	.88	.35	.07	.66	.82	.78
.68	.40	.08	.83	.11	.48	.56	.19	.46	.31
.03	.96	.49	.10	.74	.38	.22	.87	.33	.57
.70	.28	.04	.63	.27	.15	.60	.44	.03	.37
.16	.53	.85	.09	.39	.91	.47	.30	.77	.42

*Figure 3. Table of random Numbers*

- 📌 ASTM D3665 - "Standard Practice for Random Sampling of Construction Materials" is a reference used by the industry for determining random locations or timing at which samples of construction materials are to be taken. The ASTM method uses a table of random numbers and details the procedures for determining random times for belt sampling, random lengths for windrow sampling, random sampling of in-place paved materials, and random truck load number sampling.
- 📌 To obtain a group of random numbers, select a starting number in a random number table, never repeating the same starting number, and proceed from the starting number reading left to right, top to bottom, bottom to top, right to left or diagonally. Each number will then correspond to a sampling frequency.

**Example 1:**

Four samples are required for a 12 feet wide pavement with a lot size determined to be 4000 linear feet. The lot begins at station 100+00. Use the random number table in Figure 3 to determine the sample locations.

Step 1, from the given information:

Lot begins at station 100+00  
 Lot ends at station 140+00  
 Length of lot = 4,000 feet

Step 2, determine the sample location:

Using the random number table, obtain two sets of 4 random numbers each.

Set 1 will be used to determine stationing (X) of the samples by multiplying the random numbers by 4,000 feet.

Set 2 will be used to determine the sampling distance from the right edge of pavement (Y) by multiplying the random numbers by 12 feet.

Step 2a, random numbers chosen from table:

Set 1: .13    .69    .59    .88  
 Set 2: .73    .82    .46    .33

Step 2b, sample coordinate locations determined:

Sample #1:  
 $X = .13 \times 4000 = 520$  feet  
 $Y = .73 \times 12 = 8.8$  feet

Sample #2:  
 $X = .69 \times 4000 = 2760$  feet  
 $Y = .82 \times 12 = 9.8$  feet

Sample #3:  
 $X = .59 \times 4000 = 2360$  feet  
 $Y = .46 \times 12 = 5.5$  feet

Sample #4:  
 $X = .88 \times 4000 = 3520$  feet  
 $Y = .33 \times 12 = 4.0$  feet

Step 2c, samples located by stationing and offset:

Sample #1:  
Station  $100+00 + 520$  feet = Station  $105+20 @ 8.8$   
feet from right edge of pavement

Sample #2:  
Station  $100+00 + 2760$  feet = Station  $127+60 @ 9.8$   
feet from right edge of pavement

Sample #3:  
Station  $100+00 + 2360$  feet = Station  $123+60 @ 5.5$   
feet from right edge of pavement

Sample #4:  
Station  $100+00 + 3520$  feet = Station  $135+20 @ 4.0$   
feet from right edge of pavement

When obtaining samples from a large area (or lot), divide the area into sublots if necessary and obtain samples from each subplot using stratified random sampling. Stratified random sampling assures that samples are taken from throughout the entire lot and are not concentrated in one area of the lot. See Figure 4.

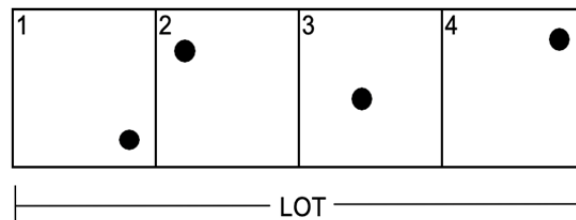



*Figure 4. Sublots for stratified sampling.*

## **SAMPLING AND TESTING RECORDS**

 All data collected during the sampling and testing processes should be documented electronically or retained on paper. This documentation provides:

- Records pertaining to individual samples.
- A process to trace samples and test results.
- Control of samples as they are processed and tested.
- Who did the sampling and testing.
- What testing was done.
- Permanent record of test data and test results.

 Sample tickets used for sample identification, work instruction cards directing which tests to perform, logs of samples and tests performed, test data worksheets, and test result reporting forms are all routinely used records which a technician must have familiarity.





 Test methods provided in AASHTO Standard Specifications, Part I/tests and in the ADOT Materials Testing Manual define which data to collect, calculations to perform, and what information to report. They also have guidelines for determining if test results are reasonable.

### **SAMPLE TICKETS**

 Sample tickets need to be attached to or accompany all samples. A sample ticket is the document which identifies an individual sample. Sample tickets will usually contain information such as:

- Project number or code.
- Name of the person who obtained sample.
- Type of material.
- Date and time the sample was obtained.
- Purpose of the sample. • Where the sample was taken
- Sample number.
- Type of testing to be performed.

## **TEST RESULTS**

-  Field sampling and testing must always be done according to test methods. Precise and reliable sampling and testing directly impacts the acceptance and payment of a product. If sampling and testing are not performed correctly, a substandard product could be accepted at full compensation or an acceptable product could be rejected. Test methods used most frequently are contained in the ADOT Materials Testing Manual and the AASHTO Standard Specifications,
-  Part II, Tests. These methods describe how large a sample should be, step-by-step procedures, what data is to be collected, what calculations are to be performed, and what test results are reported.
-  The reliability of testing is often checked with the use of split samples which are tested by two different technicians. If individual test results or the comparison of split samples do not seem reasonable, an investigation should be conducted to establish why. Usually, the discrepancy will be due to procedural or equipment deficiencies, errors in calculations, incorrect transposition of data, or the use of procedural shortcuts. Poor equipment calibration or equipment malfunction and improper handling of samples can also cause unreliable test results. Retesting should be performed only after the discrepancies have been corrected.
-  All test reports should clearly identify the individual who performed the test and the date the test was completed. Test reports should also include the signature of the individual taking responsibility for the validity of the testing. All revisions made to a test report must identify the person making the changes and the date the changes were made. Example copies of test report forms are included in some of the test methods presented in this workbook.

## **MATERIALS PROPERTIES**

-  Specific strength, durability, water dispersion and other similar properties of soils, aggregates, and asphaltic concrete are the basic properties a highway construction material is designed to satisfy. The soils and aggregate properties of interest to the field-testing technician are briefly discussed below. Compaction testing and sampling of mixtures for laboratory testing are the items of asphaltic concrete construction that are of primary interest to the field technician involved with sampling and testing.

## **ENGINEERING PROPERTIES OF SOILS**

-  Selected characteristics of soils directly influence the design, construction, and performance of highway features. The properties of soils on a construction project determine the slope of a cut, the load bearing capacity of a subgrade and the shear strength of embankments. Soils as well as aggregate base courses must have enough strength to support the applied loads of traffic, embankments, and structures under all climatic conditions. Two tests commonly used to determine the strength properties of a subgrade or embankment are the gradation and plasticity index test. These properties directly influence the soil support value of the subgrade under the pavement structure. The plasticity index is an indication of the cohesiveness, bonding, and moisture susceptibility of a soil.

- 🌱 For the purposes of this course, the engineering properties of three major soil types will be considered. Engineering properties for our use will refer to the properties of these soil types as they relate to highway design and construction.

**These three main soil types consist of:**

Granular soils-Sands and gravels



Fine-grained soils- silts and clays

Organic soils - organic clays and organic peat.



- 🌱 Granular soils, when free draining are not susceptible to frost and will settle quickly under a load. These characteristics make granular soils a good choice for use in foundations, embankments, and as wall backfill material. The drawback to the use of granular soils is that due to their high permeability it can be difficult to dewater them.
- 🌱 Cohesive soils are fine-grained soils. They sometimes possess low shear strength and are compressible and plastic. Wetting of these soils results in a further reduction of shear strength and also in expansion. The expansion will be followed by shrinkage as the material dries. Shear strength is also lost when a cohesive soil is disturbed. These soils can be subject to landslides. Cohesive soils are usually considered a poor choice for construction materials.
- 🌱 Organic refers to decayed animal and vegetable materials. Therefore, an organic soil is any soil containing enough organic material to influence the properties and characteristics of the soil. In general, organic soils are not used in highway construction. All soils, which contain an organic component, should be reviewed carefully and with suspicion when used in highway construction. The presence of organic material in the soils results in an increase in compressibility and a reduction of load bearing capacity. Organic materials can also contain toxic gases, which are released when the soil is disturbed.

***ENGINEERING PROPERTIES OF AGGREGATES***

- 🌱 Particle size and shape, gradation, and cleanliness are three important properties of aggregates that are considered in highway construction. These three properties directly influence the capability of an aggregate mixture to compact, drain water, and adhere to binders.
- 🌱 Aggregate particles are sieved through screens to obtain portions of the same **particle size**. Percentages of the different sizes are then combined to create engineered base, bedding, backfill, and mineral aggregate composites. Particle shape also influences the compactibility and surface to surface contact of aggregates. Angular and irregular particles interlock and resist displacement much better than rounded particles.

-  **Particle shape** also influences the compactibility and surface to surface contact of aggregates. Angular and irregular particles interlock and resist displacement much better than rounded particles. Particle shapes of interest include irregular, angular, flaky, elongated and rounded. Elongated particles have a long dimension which is 1.8 times the average dimension and flaky particles are those whose shortest dimension is less than 0.6 times the average dimension. Each of these shapes is determined by test methods contained later in this manual.
-  **Gradation** defines the distribution of a variety of aggregate particle sizes and is often referred to as aggregate grading. The intended use for the aggregate will determine the percentage of each particle size to be used in the gradation or size distribution. Plant screening and crushing processes are used to control gradation. Sieve analyses (AASHTO T27) are performed on an aggregate mixture to determine the true percentage of each size in the mixture.

## **ENGINEERING PROPERTIES OF ASPHALTIC CONCRETE**

-  Field sampling of asphaltic concrete mixes is performed to check the produced mix properties for compliance with mix design requirements. Asphaltic concrete mixture performance is affected by the mineral aggregate properties and liquid asphalt cement properties. Consequently, it is important that representative samples are taken. The common method for sampling asphaltic concrete mats is to place a 1' x 4' metal plate in front of the paver. As the paver travels across the plate, material is placed on the plate. When obtaining the asphaltic concrete sample from the surface of the plate, all slough material from the sides of the cut of the surface should not be collected.
-  Asphalt cements function as a binder, or glue, which hold the aggregate particles together and provide protection against the effects of water. Liquid asphalt cement samples are taken to check viscoelastic, temperature sensitivity and aging properties.

## **COMPACTION**

-  Asphaltic concrete, soils and aggregate bases, backfills and beddings are typically compacted to a specified percentage of maximum density in the field by use of rollers or mechanical compactors. Maximum compaction is desirable to reduce settling and deformation, and increase load bearing capacity. The density of a layer of in-place soils/aggregate material is checked by the sand cone density test (AASHTO T191), nuclear density gauge (AASHTO T310), or one-point proctor test (AASHTO T271). Asphaltic concrete compaction is checked with the nuclear density gauge (AASHTO T355) or lab testing of cores (AASHTO T67) taken from the compacted roadway. The in-place density of soils/aggregates is then compared to the maximum dry density determined in the lab by proctor testing to determine the degree of compaction. Similarly, the in-place density of a layer of compacted asphaltic concrete is compared to the maximum density determined by laboratory testing.



# TEST METHODS





EITHER SCAN OR CLICK ON THE QR CODE FOR VIDEOS

## SAMPLING PROCEDURES

Field construction materials sampling is a critical process in ensuring the quality, safety, and longevity of construction projects. Field sampling involves collecting representative samples of various construction materials, mainly soil, concrete, asphalt, binder, and aggregates directly from the construction site, plant, or transport for analysis. Proper sampling techniques and analysis are essential for overall quality and longevity of construction projects.

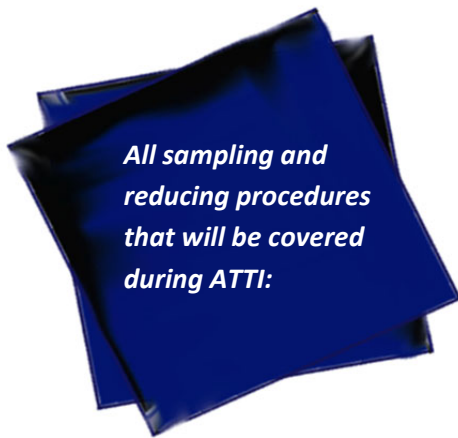

- **AASHTO R90: SAMPLING AGGREGATE PRODUCTS**
- **AASHTO R97: SAMPLING ASPHALT MIXTURES**
- **AASHTO R66: SAMPLING ASPHALT MATERIALS**
- **AASHTO R76: REDUCING SAMPLES OF AGGREGATE TO TESTING SIZE**
- **AASHTO R67: SAMPLING ASPHALT MIXTURES AFTER COMPACTION (CORES)**

Learning objectives for these sections are:

- 🌱 **How to obtain a representative sample of aggregate, asphalt mixtures, and asphalt materials through various methods.**
- 🌱 **How to reduce samples, once collected, to their appropriate testing sizes.**
- 🌱 **Learn the basic terminology for sampling techniques, the kinds of materials used in construction processes, and the kinds of equipment the technician will encounter on site.**



PLEASE REFER TO THE PROCEDURE FOR MORE DETAIL. NOT ALL SECTIONS WILL BE COVERED BY ATTI. THE SECTION NUMBER WILL BE PROVIDED FOR REFERENCE.



# AASHTO R90: SAMPLING AGGREGATE PRODUCTS

SEC:

## DEFINITIONS:

**Nominal maximum size** - is the smallest sieve size through which the majority of the sample passes (up to 15% can be retained).

**Windrow** - is a long ridge of loose construction material.

**Stockpile** - is a collection of materials in piles that are segregated by type & size and intended for specific uses on a construction site.

**Increment** - is a portion of material that is collected by a sampling device in a single operation.

## SCOPE:

1.1.

This practice covers the procedures for obtaining representative samples of coarse, fine, or combinations of both to determine compliance with all relevant specifications.

## EQUIPMENT:

4.0.

- **SHOVELS OR SCOOPS**
- **BROOMS, BRUSHES, AND SCRAPING TOOLS**
- **MECHANICAL SAMPLING SYSTEMS-** Normally, a permanently attached device that allows a sample container to pass perpendicularly through the entire stream or diverts the material into the container.
- **BELT TEMPLATE-** a device that is the shape and width of the aggregate belt.
- **SAMPLING CONTAINERS**

## PROCEDURE:

- Make sure to **clean and dry** all **equipment and containers** before sampling.
- Field **samples** should meet or exceed **TABLE 1** found in the procedure.
- **Sample size is based upon the tests that are required.** Rule of thumb, generally the sample should be enough that if you split it twice you should end up with the approximate testing size amount.

5.1.1

5.2.

5.2.N1

**Table 1—Recommended Sample Sizes**

Nominal Maximum Size		Minimum Mass	
mm	(in.)	kg	(lb)
90	(3½)	175	(385)
75	(3)	150	(330)
63	(2½)	125	(275)
50	(2)	100	(220)
37.5	(1½)	75	(165)
25.0	(1)	50	(110)
19.0	(¾)	25	(55)
12.5	(½)		
9.5	(¾)		
4.75	(No. 4)		
2.36	(No. 60)		



**Record the sampling time or location or both. If being used for quality control or acceptance use a random sampling procedure to obtain the time and location.**

**SAMPLING FROM CONVEYOR BELT USING A TEMPLATE:**

By taking regular samples from the conveyor belt, technicians can obtain their representative samples at the production facility. This allows for corrective actions to be taken before potentially substandard aggregate is used or transported to the job site. (The method of sampling a technician employs are generally project and/or agency specific.)

**1** Have the **belt stopped**.

5.3.1

**2** Set the **sampling template** on the **belt** in a way that avoids adjacent material from falling into the space inside the template.

5.3.2

**3** **Remove** the material from **INSIDE** the **template**; **including** any **material adhering** to the belt utilizing scoops and brushes.

5.3.3

**4** If that increment is not enough **repeat the process** obtaining equal increments each time. **Combine** the increments to form a **single sample**.

5.3.4

**i** When sampling aggregate from the conveyor belt avoid sampling from the beginning or the end of the aggregate run to avoid segregation of material.

**!** Be careful when sampling in the rain it can make removing the finer material more difficult.



Clean all material (including fines) off belt.

**SAMPLING FROM CONVEYOR BELT DISCHARGE:**

Similar to sampling from the conveyor belt with a template, this form of sampling can be utilized and may be easier to accomplish in certain instances. By taking regular samples from the conveyor belt, in general, technicians can obtain their representative samples at the production facility. This allows for corrective actions to be taken before potentially substandard aggregate is used or transported to the job site. (The method of sampling a technician employs are generally project and/or agency specific.)

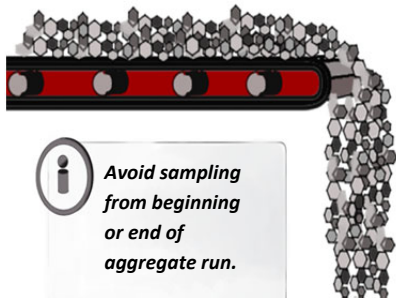

Sampling Device

**1** The **sampling device** (manual or automatic) must be passed through the **full stream** of material as it runs off conveyor belt.

5.4.

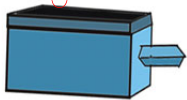

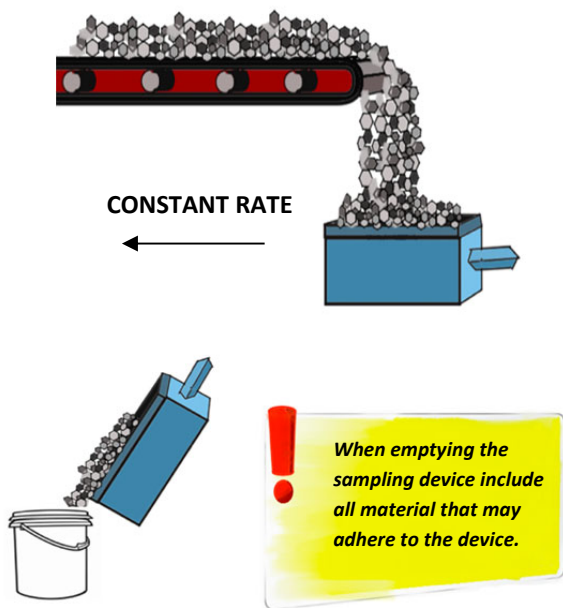

- 2 Pass the **sampling device** through the full stream of material **once in each direction**. Sampling must be done at a **constant speed** and **perpendicular** to the flow of the material **without overflowing**. 5.4.1
- 3 **Empty** the sampling device into an appropriate **sampling container**. *Considered 1 increment.* 5.4.1
- 4 If that increment is **not enough** repeat the process obtaining equal increments each time. **Combine the increments** to form a **single sample**. 5.4.2

**SAMPLING FROM TRANSPORT UNITS:**

Sampling from transport units ensures that samples taken are representative of the entire batch being delivered to the job site. This ensures that the material actually delivered conforms to the required specifications. *(The method of sampling a technician employs are generally project and/or agency specific.)*

- 1 **Visually divide** the transport unit into **four quadrants**. 5.5.1
- 2 Pick **one quadrant** and identify a **random sampling location** within. 5.5.2
- 3 Remove approximately **1 ft** of material from sampling area. **Obtain an increment** from the exposed surface and **repeat procedure** in each of the remaining quadrants. **Combine** increments into one sample. 5.5.3

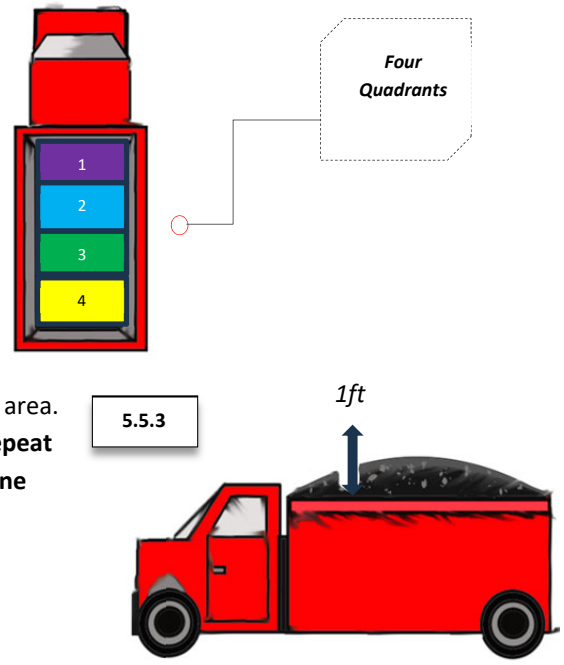

**SAMPLING FROM ROADWAY – BERM OR WINDROW:**

*Sampling aggregate and soils from a windrow (a long pile or ridge of material) or berm (a raised strip or mound of material) is an essential procedure in obtaining a representative sample for later testing at the job site itself. (The method of sampling a technician employs are generally project and/or agency specific.)*



WINDROW



BERM

**Make sure NOT to take the sample or any increment from the beginning or end of the windrow or berm.**

**1** Remove the top 1/3 of the windrow or berm before taking increment.

5.6.1

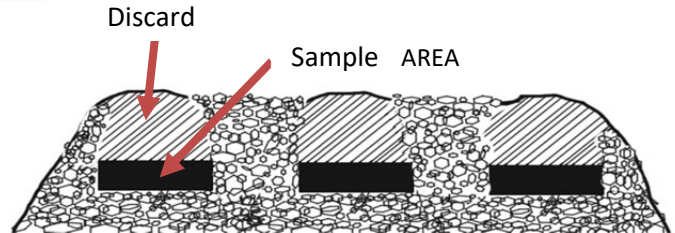

**2** Obtain a minimum of 3 approximately equal increments from random locations along the windrow or berm.

5.6.3

**3** Fully insert the shovel into the location (exclude underlying material), roll back and lift the shovel slowly so as not to lose any material. Combine the increments to form a single sample.

5.6.3.1

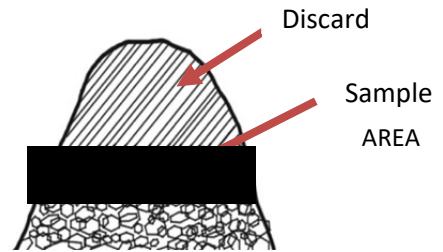

SIDE VIEW

**SAMPLING FROM ROADWAY- INPLACE:**

*Sampling aggregate and soils from the roadway in place is a commonly quick but least sophisticated way to obtain representative samples for analysis. (The method of sampling a technician employs are generally project and/or agency specific.)*

**1** Obtain representative sample after spreading and before compacting.

5.7.1.

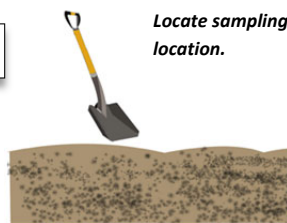

Fully insert the shovel to the full depth of the material. Excluding underlying material.



Roll back the material avoid material rolling off. Repeat procedure in at least 3 random locations.

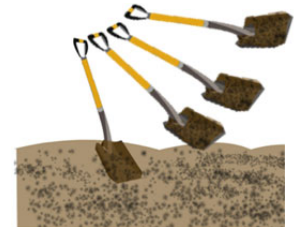

**SAMPLING FROM STOCKPILE – FRONT LOADER PAD:**

*Stockpiled materials often experience segregation, where fine particles settle at the bottom and larger particles accumulate at the top and the sides. Using a front loader to sample and mix material from different layers of the stockpile helps ensure that the sample taken is representative of the entire stockpile, rather than just the surface or just one section. (The method of sampling a technician employs are generally project and/or agency specific.)*



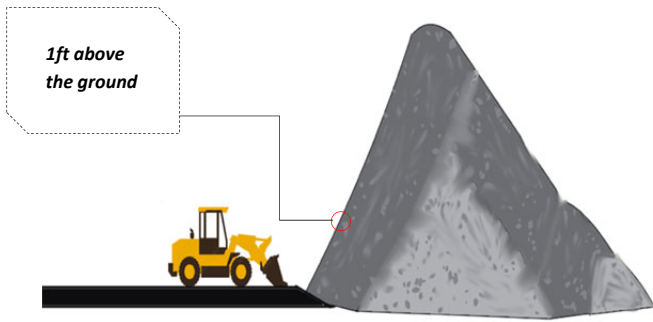

**1** The **front loader** must enter the stockpile with the bucket at least **1ft above** the ground. 5.8.1.1

**2** Discard the **1<sup>st</sup>** bucket full. 5.8.1.2

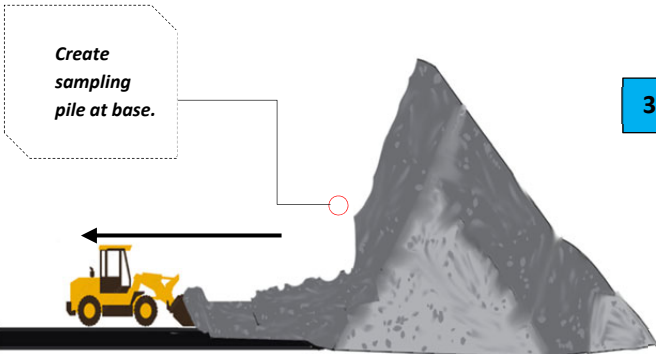

**3** Have the front loader **re-enter** the stockpile securing another **bucket full**. Keep taking buckets full until desired amount is obtained. Create a small **sampling pile at the base** of the stockpile by gently rolling the material out of the bucket. **Repeat as necessary**. 5.8.1.3

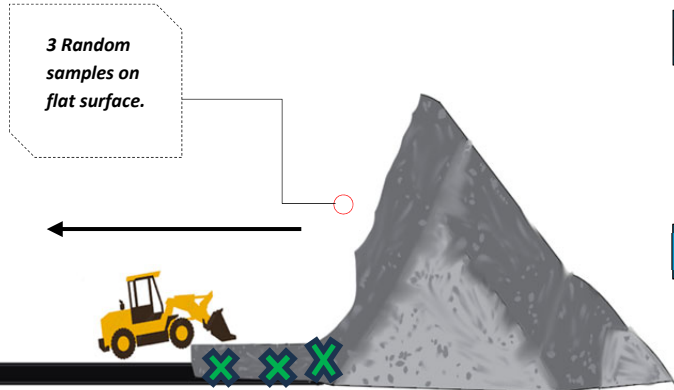

**4** Have the loader create a **flat surface** by back dragging the pile. Obtain **increments** from at least **3 randomly** selected locations on the flat surface at least **1 ft** from the edges. 5.8.1.6

**5** **Fully insert the shovel** into the location and lift shovel slowly so as not to lose any material. **Combine** each increment to form a **single sample**. 5.8.1.7

**SAMPLING FROM STOCKPILE – HORIZONTAL SURFACE ON FACE:**

*Sampling from the face of the stockpile utilizing the following procedure helps mitigate some of the material segregation issues had while obtaining a representative sample from a material stockpile. (The method of sampling a technician employs are generally project and/or agency specific.)*

**1** Create **horizontal surfaces** with vertical faces in the **top, middle, and bottom third** of the stockpiles with a shovel or loader.

5.8.2.1

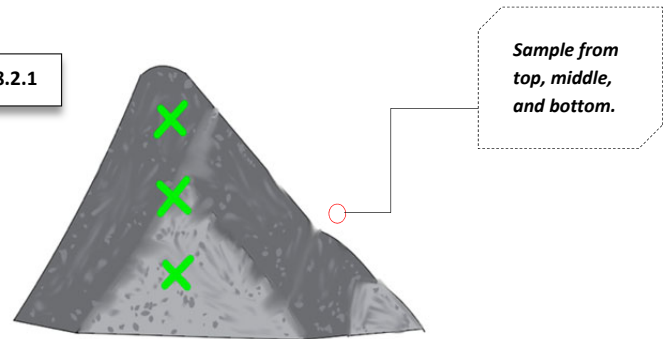

**2** Insert a flat board against the **vertical face** behind sampling location to prevent sloughing. Discard slough material to create horizontal surface.

5.8.2.2

**3** Obtain sample from the horizontal surface as close as possible to the **intersection of the horizontal and vertical faces**.

5.8.2.3

**4** Obtain at least **1 increment** of equal size from **each of the top, middle, and bottom thirds** of the pile. Combine all increments into a single sample.

5.8.2.4

Flat board / shield

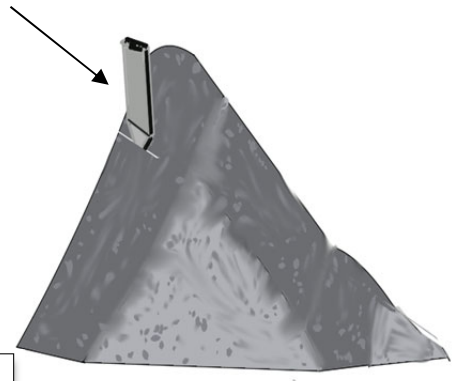

Intersection

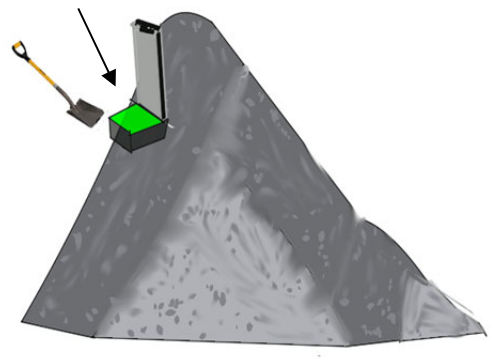

**IDENTIFICATION & SHIPPING (example)**

**IDENTIFICATION & SHIPPING:**

*Date*  
*Time*  
*Sampling Location*  
*Quantity of Material (if applicable)*  
*Material Type*  
*Supplier*

6.

- Please refer to approved agency or companies' internal procedures and forms. This EXAMPLE in no way indicates all that may be required.

**!** Please refer to the standard for any material not cover.

**SECTIONS NOT COVERED:**

**SAMPLING FROM STOCKPILE – FINE AGGREGATE (ALTERNATE TUBE METHOD:)**

PLEASE REFER TO THE SECTION FOUND IN THE PROCEDURE FOR MORE DETAIL IF INTERESTED. THIS PROCEDURE IS NOT COVERED OR TESTED ON DURING ATTI CERTIFICATION.

5.9.

# AASHTO R97: SAMPLING ASPHALT MIXTURES

## DEFINITIONS:

**Asphalt Mixture** – is a composite of asphalt (binder), aggregates, and other components used to pave roads and parking lots.

**Asphalt paver** – is a machine used to lay, spread, and compact asphalt.

**Paver auger** – is a screw like component on an asphalt paver that moves asphalt product from the conveyor to screed.

**Compaction (Asphalt)** – is the process of reducing the volume of asphalt and aggregate in hot mix asphalt concrete by applying external forces.

## SCOPE:

1.1.

*This standard covers the procedures for sampling of asphalt mixtures at point of manufacture, storage, and delivery.*

## EQUIPMENT:

4.

- **SAMPLING CONTAINERS**
- **MECHANICAL SAMPLING SYSTEMS** – a permanently attached device that allows a sample to pass through the entire stream of material.
- **SHOVELS OR METAL SCOOPS** – shovels at least 5.5 inches wide.
- **BELT TEMPLATE**- A template that is the width and shape of the asphalt mixture stream belt.
- **SAMPLING PLATE** – Thick metal plate, minimum 8 gauge, sized to accommodate sample size requirements. Wire long enough to reach from center of paver to outside of farthest auger extension. Each corner of the plate should have 0.25-inch diameter hole.
- **COOKIE CUTTER SAMPLING DEVICE** – Steel angle with two 100mm by 150mm by 9mm handles sized to accommodate sample size. Minimum 2 inches smaller than the sampling plate when used together.
- **RELEASE AGENT** – nonstick spray.

## PROCEDURE:

- Make sure asphalt samples are **covered** to prevent contamination.

5.1.2

**When sampling asphalt mixtures, utilize random sampling or stratified random sampling. Select a minimum of 3 locations to best represent the material being tested.**

- Consult the **test method OR agency specifications** for a sample size.
- Make sure the **containers** and sampling **equipment** are **clean and dry** before sampling.

5.2.

5.3.1

*If using containers that are made of absorbent materials and the mix is hot open-graded mixture then allow to cool in stainless steel bowls or pans first so there is no loss of binder.*

**SAMPLING USING ATTACHED SAMPLING DEVICE:**

**1** An **attached sampling device** is defined as permanent and allows a sampling receptacle to **pass through** a stream of asphalt mixture **perpendicularly twice**, once in each direction without overfilling.

5.4.1.

**2** Lightly coat the attached receptacle with a **release agent** or **preheat** it, or both.

5.4.2.

**3** Pass the receptacle **twice through** the material **perpendicularly** without overfilling.

5.4.3.

**4** **Transfer** from sampling receptacle to **sample container** without loss of material. Repeat until you have the proper sample size.

5.4.4.

*As an alternative the stream of asphalt mixture can be entirely diverted to get a representative sample.*

**SAMPLING FROM TRANSPORT UNITS:**

*Transport units are, essentially, any vehicle approved to haul asphalt materials. Sampling from these vehicles is essential to ensure that the material being delivered to the construction site meets quality control standards and complies with project specifications. (The method of sampling a technician employs are generally project and/or agency specific.)*

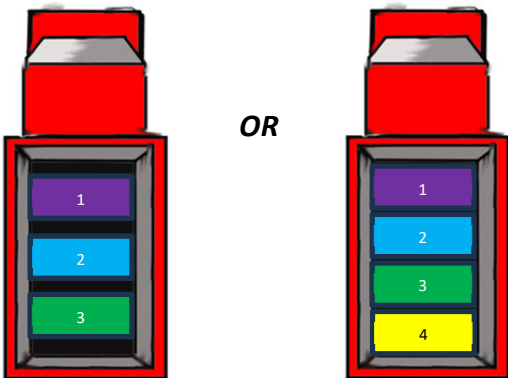

**1** Visually **divide** the unit into **three or four** equal sections.

5.6.1

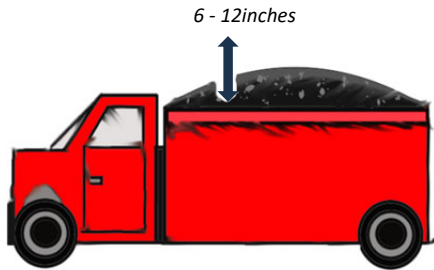

- 2 Remove approximately **6 to 12 inches** of material from the section you have decided to sample from. 5.6.2
- 3 **Obtain an increment** from the exposed surface of that section. Repeat for the remaining sections. 5.6.3
- 4 **Combine** all increments into **one sample**. 5.6.3

**SAMPLING FROM A WINDROW:**

*When on site, the technician has an option to obtain their representative sample from a windrow which is a continuous, long pile, usually using a bottom-dump truck, where the material is deposited in a controlled manner to form a row of loose asphalt. This method is widely used in the industry. (The method of sampling a technician employs are generally project and/or agency specific.)*

- 1 Visually **divide** the windrow into approximately **3 equal** parts. 5.8.2.
- 2 Remove approximately **1 ft** from the **top** of the windrow. 5.8.3.
- 3 Obtain **approximately equal** sample increments by fully inserting the shovel into the flat surface as vertically as possible roll back and lift. Take care to exclude underlying material.
- 4 **Place the increment** into the **sample container** and repeat for the remaining thirds. 5.8.3.
- 5 **Combine** all increments to form **one sample**. 5.8.3.

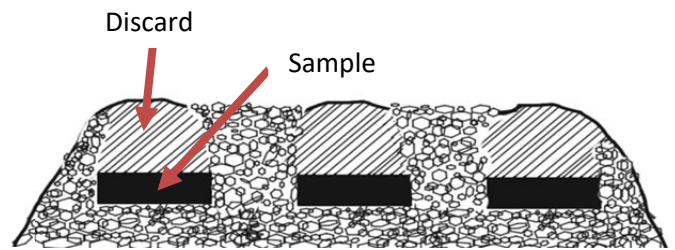

5.8.3.

! **Make sure not to take any increment from the beginning or end of the windrow.**

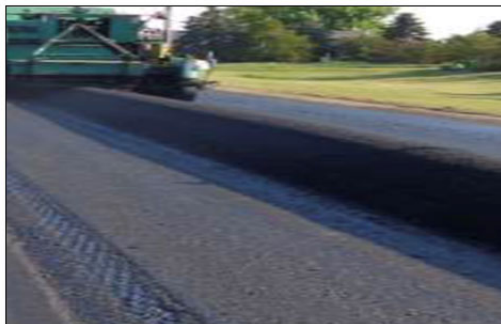
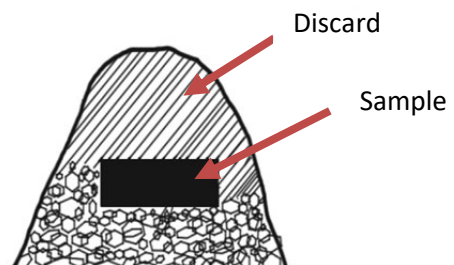

**SAMPLING PLATE METHOD:**

*The plate method allows for the collection of a representative sample from a continuous asphalt layer being placed by the paver on grade or base material. Asphalt mixtures can vary slightly in its properties during placement it's important to obtain a sample that reflects the material being actually placed on the road. (The method of sampling a technician employs are generally project and/or agency specific.)*



**1** The **plate** is to be placed at least **10 ft in front** of the paver. 5.9.2.1.1.

**2** No technician is to be between the supply trucks and paver unless supply truck is moving forward. If this is the case then the **technician** needs to be at least **10 ft behind** the truck. 5.9.2.1.2.

**3** Remove loose material at least **2ft inside the edge of the mat.** 5.9.2.1.4

**4** Lay down the plate **diagonally** with the **direction of travel** of the paver. The technician must keep the plate flat and tight to the base with the lead corner facing the paver. 5.9.2.2.

**5** **Hold** the **wire** attached to the outside corner of the plate **taut** as the paver operation passes over. 5.9.2.3

**!** *The technician (if possible) must have contact and communication with the paving machine for safety. If not possible have a third party to assist.*

**6** Pull the **wire up** through the asphalt mixture to locate the corner of the plate. 5.9.2.5

**7** Using a **square pointed shovel** remove the **full depth** of the mixture from the plate. 5.9.2.6  
Take care to prevent sloughing of adjacent material.

**8** Place **all material** including all that adheres to the plate into **sample container**. 5.9.2.7

**9** **Remove the plate** from the roadway. The **hole** left must be **filled** with loose asphalt before compaction. 5.9.2.7



**SAMPLING FROM STOCKPILES (ASPHALT):**

• Remove at least **4 inches** from the surface before sampling. Asphalt mixtures in stockpiles may develop an oxidized crust. 5.10.2.

• Also, if sampling from an **Asphalt Stockpile** with a front loader the **first bucketful** does **not** have to be **discarded**. 5.11.1.

**i** *Otherwise, all other procedures relating to sampling from stockpiles are identical to R90 Sampling from Stockpiles.*

**IDENTIFICATION & SHIPPING (example)**

**IDENTIFICATION & SHIPPING:**

*Date*  
*Time*  
*Sampling Location*  
*What type of Sampler*  
*Asphalt Mixture Supplier*  
*Sampling Location*  
*Purpose of Sample*  
*Quantity*  
*Type*

**SECTIONS NOT COVERED:**



**SAMPLING FROM CONVEYOR BELT  
USING A TEMPLATE:**

See section 5.5. (Procedure is identical to AASHTO R90:  
SAMPLING FROM CONVEYOR BELT USING A TEMPLATE)

5.5.

**SAMPLING FROM A PAVER AUGER:**

PLEASE REFER TO THE SECTION FOUND IN THE PROCEDURE  
FOR MORE DETAIL IF INTERESTED. THIS PROCEDURE IS NOT  
COVERED OR TESTED ON DURING ATTI CERTIFICATION.

5.7.1

**PLATE METHOD- PLATE WITH COOKIE CUTTER:**

PLEASE REFER TO THE SECTION FOUND IN THE PROCEDURE  
FOR MORE DETAIL IF INTERESTED. THIS PROCEDURE IS NOT  
COVERED OR TESTED ON DURING ATTI CERTIFICATION.

5.9.2.8.

**NON-PLATE METHOD:**

PLEASE REFER TO THE SECTION FOUND IN THE PROCEDURE  
FOR MORE DETAIL IF INTERESTED. THIS PROCEDURE IS NOT  
COVERED OR TESTED ON DURING ATTI CERTIFICATION.

5.9.3.

**SAMPLING FROM A PAVER HOPPER:**

PLEASE REFER TO THE SECTION FOUND IN THE PROCEDURE  
FOR MORE DETAIL IF INTERESTED. THIS PROCEDURE IS NOT  
COVERED OR TESTED ON DURING ATTI CERTIFICATION.

5.10.1.

**SAMPLING FROM ASPHALT STOCKPILE –  
FRONT LOADER:**

See section 5.11.1 (Procedure is identical to AASHTO R90:  
SAMPLING FROM STOCKPILE -FRONT LOADER exception see  
note under Sampling from Stockpiles (asphalt).

5.11.1

**SAMPLING FROM ASPHALT STOCKPILE –  
HORIZONTAL SURFACE ON FACE**

See section 5.11.2. (Procedure is identical to AASHTO R90:  
SAMPLING FROM ASPHALT STOCKPILE – HORIZONTAL  
SURFACE ON FACE) exception see note under Sampling from  
Stockpiles (asphalt).

5.11.2.





# AASHTO R66: SAMPLING ASPHALT MATERIALS

## DEFINITIONS:

**Asphalt Binder**- is a black viscous material created from petroleum refining. Acts as the glue that holds together the aggregates in asphaltic concrete.

**Emulsions** – are a liquid mixture of asphalt, water, and an emulsifying agent that is used in road construction and maintenance.

**Asphalt Cement Grades** – types of asphalt binder that vary in consistency and flow resistance.



### SIZE OF CONTAINER:

- Size of container must accommodate the required amount of the sample.

### SCOPE:

1.1

*This method covers sampling of asphalt materials at production facilities, storage facilities, transport units, or at the point of delivery.*

### SIZE OF SAMPLES

#### MINIMUM SAMPLE SIZE:

- 1 Quart of Asphalt Binder
- 1 Quart of Emulsified Asphalt

4.1.1

4.1.2

### CONTAINERS:

#### TYPE OF CONTAINER:

##### *For Liquid Asphalt (not emulsions):*

5.1.1

- Double-seal friction-top can.
- Square Cans with screw tops.
- Small mouth cans with screw caps.

##### *For Emulsions:*

5.1.2

- Plastic wide-mouth jars.
- Bottles with screw caps.

**PROTECTION & PRESERVATION:**

- All sample containers will be **new** and the **top will fit** together with the container **tightly**. 6.1.
- To **prevent contamination**, fill the container and tightly seal it. 6.2.
- **Protect** emulsified asphalt samples from **freezing**. 6.4.
- **DO NOT** sample emulsified asphalt under pressure. 6.4.
- **Transferring** samples from one container to another shall be **avoided**. 6.5.
- Properly **identify** the sample containers with a suitable marker after filling, sealing, and cleaning. **Write on the body** of the container itself. 6.6.
- **Do not** write on the lid. 6.6.

**IF A CONTAINER NEEDS CLEANING CAN THE TECHNICIAN USE SOLVENT?**

*No solvent can be used on any sampling container. If the container needs cleaning only a clean dry cloth.*

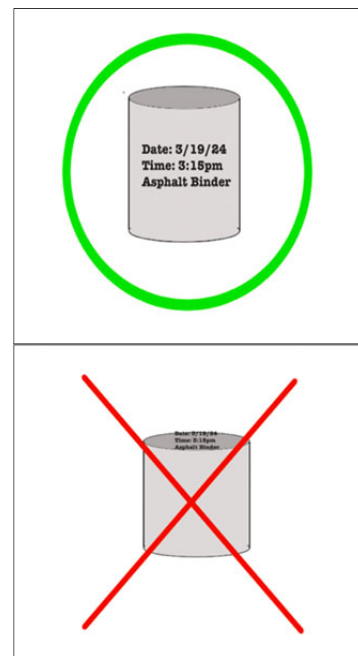

*If labels are used, they have to be securely fastened to container. All identification materials must maintain integrity at temperatures up to 392 degrees Fahrenheit.*

**IDENTIFICATION & SHIPPING:**

Date  
Material Source  
Type

MINIMUM INFO

**PROCEDURE:**

*The following methods within the procedure are applicable to both emulsions and binder unless stated otherwise.*

*Sampling emulsions at various points in the production or delivery process (e.g., from the tank, transport units, or the distributor truck), allows you to verify that the emulsion is consistent and homogeneous, and adheres to all applicable specs and provisions.*

*Sampling asphalt binder is important in understanding how the asphalt mix performs in terms of durability, flexibility, and resistance to wear. It allows for the verification of binder quality, consistency, and compliance with the specifications and standards for the project.*

### SAMPLING AT PLACE OF MANUFACTURE

- (BULK STORAGE TANKS NOT EQUIPPED WITH MECHANICAL AGITATORS (LIQUID ASPHALT MATERIALS OR MATERIALS LIQUEFIED BY HEATING)):

#### TANK TAP METHOD:

**1** Use the **valves** or taps at the **top, middle, and lower** locations of the tank to obtain sample after clearing out the line.

7.1.1.



**2** If there is only **one valve** available at the **bottom** then draw off your **entire sample** after clearing out the line from that valve.

7.1.1

- (BULK STORAGE TANKS EQUIPPED WITH MECHANICAL AGITATORS (LIQUID ASPHALT MATERIALS OR MATERIALS LIQUEFIED BY HEATING)):

**1** A **single sample** is taken by the same method as section 7.1.1 & 7.1.2.

7.2.

#### CLEARING OUT THE LINE:

*When sampling it's mandatory to clear out the line by drawing and discarding a minimum of 1 Gallon of material.*

### SAMPLING FROM TANK CARS, VEHICLE TANKS, OR DISTRIBUTOR TRUCKS:

The valve is, generally, located near the pump within the recirculation line.

**1** Vehicle will be equipped with sampling valve.

8.1.

ASPHALT DISTRIBUTOR TRAILER



Some alternatives to obtaining representative samples (if allowed by the purchaser)

- **DIP METHOD**- taking a clean container to dip in and obtain a sample and immediately transferred to a new clean appropriate sample.

8.2.1

2

The **valve** will be installed at least **1 ft from the shell** and have a sampling valve label.

8.1.

3

**Before** the sample is taken a minimum of **1 gallon** will be **drawn** from the sample valve and **discarded**.

8.1

- **NOZZLE ON SPRAY BAR**- sample from flushed spray bar nozzle.

8.2.3

- **DETACHABLE OR PERMANENT PIPE FITTING**- Similar design as the below image. This will be inserted into the discharge line that is located between the unloading pipe and hose as close to the end as possible. Take the sample after 1/3 and not more than 2/3 of the load has been removed. Remember to draw and discard 1 gallon before taking the sample.

8.2.2.

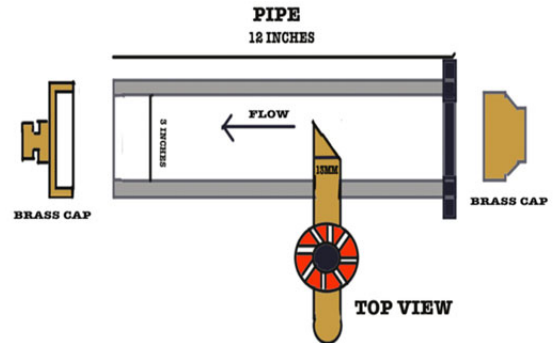

**SAMPLING FROM PIPELINES DURING ASPHALT BINDER PRODUCTION (HMA HOT PLANT):**

- 1 Obtain the sample from the **line feeding** the mixing plant while the plant is in operation.

11.1.

- 2 The sampling valve will be located **downstream** of the mixing and blending process takes place.

11.1.

- 3 The **diameter** of the sampling pipe will not be more than **1/8<sup>th</sup> of the diameter** of the **pipe line** and its opening should be turned to face the flow of the liquid.

11.1.

- 4 Before the sample is taken a minimum of **1 gallon** will be **drawn** from the sample valve and **discarded**.

11.1.

**SAMPLING AT POINT OF SHIPMENT DELIVERY:**

**1** Sampling must be performed as **soon as possible** after the asphalt material arrived at the plant site, storage site, or job site. 14.1.

**2** Follow the method for sampling from **Section 7**  
OR :

14.3.1

**!** Follow your agencies rules for the required number of samples to be taken. For small delivery units take samples necessary to represent a maximum of 10000 gallons.

**3** Bleeding through a sample valve or tap in the transfer line during the unloading of the **middle third** of the load. Remember to **draw and discard 1 gallon** before taking sample. 14.3.2.

**i** Tests for acceptability will be performed on one of the samples taken. Retain the other samples for retesting if the first fails.

- **SAMPLING AT POINT OF SHIPMENT DELIVERY IS GENERALLY DONE ON EMULSIONS.**

**!** Please refer to the standard for any material not cover.

**SECTIONS NOT COVERED:**

**THIEF SAMPLER METHOD (NOT SUITABLE FOR ASPHALT BINDERS):**

PLEASE REFER TO THE SECTION FOUND IN THE PROCEDURE FOR MORE DETAIL IF INTERESTED. THIS PROCEDURE IS NOT COVERED OR TESTED ON DURING ATTI CERTIFICATION.

7.1.2.

**SAMPLING FROM TANKERS & BARGES:**

PLEASE REFER TO THE SECTION FOUND IN THE PROCEDURE FOR MORE DETAIL IF INTERESTED. THIS PROCEDURE IS NOT COVERED OR TESTED ON DURING ATTI CERTIFICATION.

9.1.1.

**SAMPLING FROM PIPELINES DURING LOADING  
& UNLOADING:**

PLEASE REFER TO THE SECTION FOUND IN THE PROCEDURE FOR MORE DETAIL IF INTERESTED. THIS PROCEDURE IS NOT COVERED OR TESTED ON DURING ATTI CERTIFICATION.

10.1.

**SAMPLING FROM DRUMS & BARRELS:**

PLEASE REFER TO THE SECTION FOUND IN THE PROCEDURE FOR MORE DETAIL IF INTERESTED. THIS PROCEDURE IS NOT COVERED OR TESTED ON DURING ATTI CERTIFICATION.

12.1.

**SAMPLING SEMISOLID MATERIALS:**

PLEASE REFER TO THE SECTION FOUND IN THE PROCEDURE FOR MORE DETAIL IF INTERESTED. THIS PROCEDURE IS NOT COVERED OR TESTED ON DURING ATTI CERTIFICATION.

13.1.

# AASHTO R76: REDUCING SAMPLES OF AGGREGATE TO TESTING SIZE

**DEFINITIONS:**

**Coarse Aggregate** - is a granular or irregular material that is typically larger than #4 (4.75mm) screen and is used in concrete.

**Fine Aggregate** - are the particles that pass through a #4 (4.75 mm) sieve and retain on a #200 (0.075mm) sieve.

**Splitting** - is the process of dividing a sample of aggregate into fractions that contain particles within specific limits. The resulting particle size distribution is called the gradation.

**Saturated Surface Dry** - the condition of the aggregate when all permeable pores of each particle are completely saturated with water and its surface has no free moisture.



This standard covers the reduction of large samples of aggregate to the right size for testing.



- The following is quick reference on the method selection for reducing common types of material. There will be a detailed description of each method with the type of equipment used.



**!** If the technician wants to utilize METHOD B or METHOD C. The sample can be moistened, and thoroughly mixed.

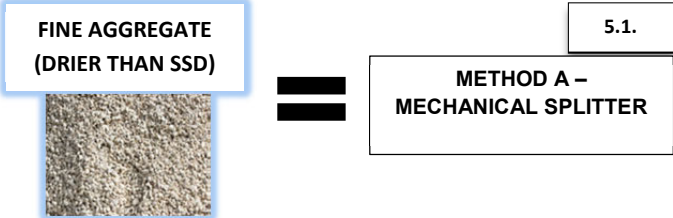



**If the technician desires to utilize METHOD A for Fine Aggregate wetter than SSD. The entire sample can be dried to at least the SSD condition using temperatures that doesn't exceed specs for other potential testing.**

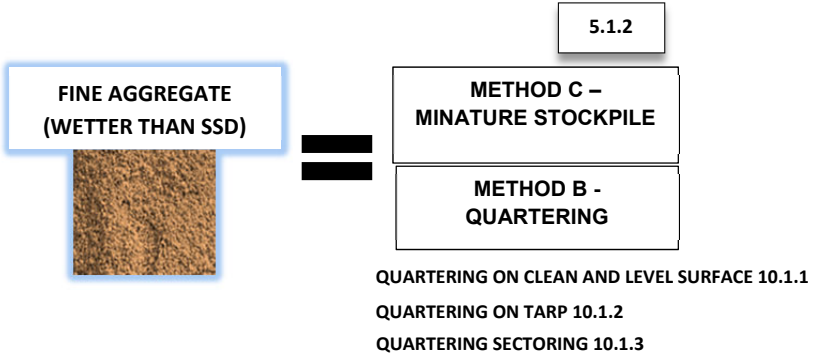

**GOAL OF REDUCING:**  
Example of particle distribution of aggregate BEFORE reduction.

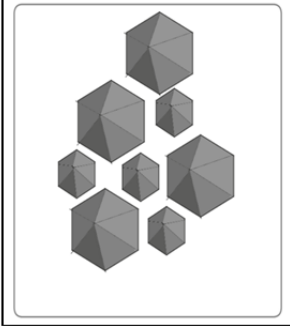

**i** *If the moist sample is very large a preliminary split can be made using a mechanical splitter with chute opening of 1 1/2 inches or more. The sample can't be reduced less than 5000 grams.*

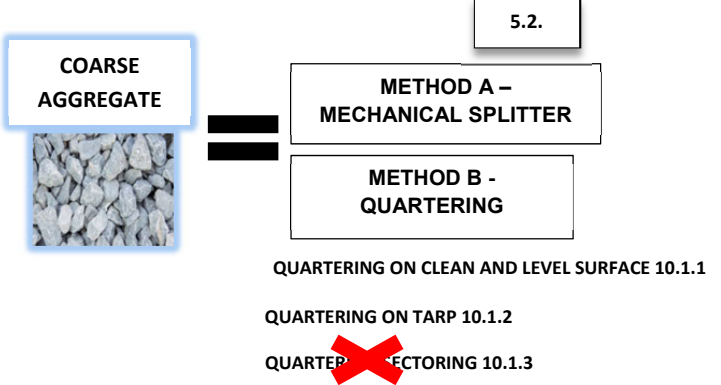

**GOAL OF REDUCING:**  
Example of particle distribution of aggregate AFTER reduction.

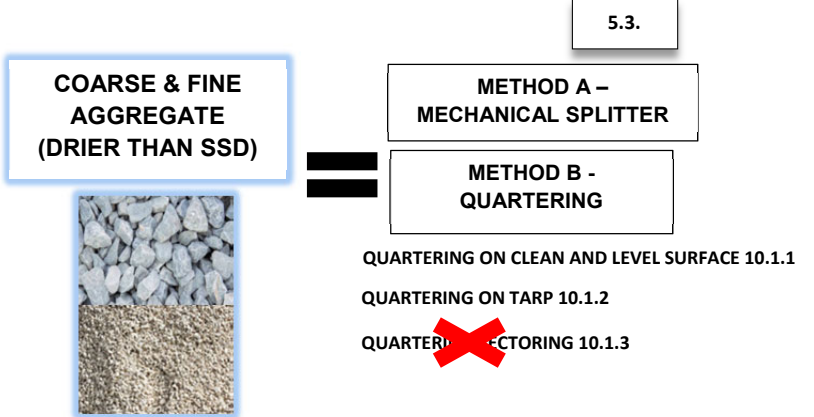
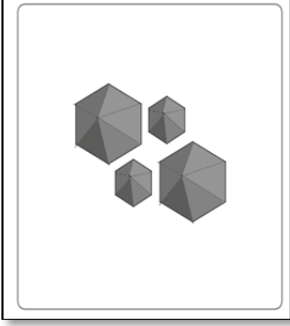

**i** *Determining saturated surface-dry condition is if the fine aggregate will retain its shape when molded in the hand.*

**EXAMPLE:** Aggregate Base Material

**If the technician finds it advantageous to utilize METHOD A the entire sample may be dried to where it appears dry or until clumps can be broken up, using temperatures that don't exceed any specs other potential testing.**

**COARSE & FINE AGGREGATE (WETTER THAN SSD)**



5.3.

**METHOD B - QUARTERING**

QUARTERING ON CLEAN AND LEVEL SURFACE

QUARTERING ON TARP 10.1.2

QUARTERING IN CONVEYOR 10.1.3



*The dryness of a sample can be tested by squeezing tightly a portion of the material in your hand. If it crumbles easily, you've reached the correct moisture.*

*Splitting aggregate down to size is necessary in the process of construction materials testing. It enables technicians to ensure that the material is representative, the aggregate is properly distributed, and is the amount indicated in the test method. The process allows for accurate testing of gradation, moisture content, and other performance characteristics.*

**METHOD A – MECHANICAL SPLITTER:**



**SAMPLE SPLITTER:**

- Sample splitters **MUST** have an **even number** of equal-width chutes. At least **8 chutes** for coarse aggregate, and **12 chutes** for fine aggregate.
- Discharge will be on either side of the splitter with **two receptacles** to catch the material.
- If the material is **coarse or mixed aggregate** then the **minimum width** of the chutes will be approximately **50% larger** than the **largest particle**.

7.1.

7.1.

7.1.

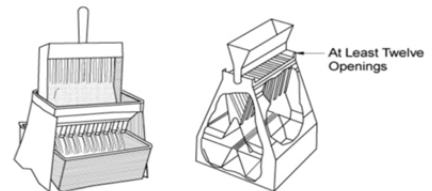

(b) Small Sample Splitters for Fine Aggregate



(a) Large Sample Splitter for Coarse Aggregate

- If the material is **dry fine aggregate** that 100% which entirely passes the 3/8" screen the **minimum width** of the individual chutes shall be at least **50% larger** than the largest particle and the **maximum width will be 3/4"**.

7.1.



*The mechanical splitters for coarse aggregate should be used on particles 1 1/2" or less.*

**PROCEDURE:**



- 1** Place the sample in the **hopper or pan** and distribute sample from **edge to edge**. Introduce at a **rate** that allows the material to **flow freely** through the chutes.

8.1.

- 2** Keep **splitting** until the sample is **reduced** to the size for the specific test desired.

8.2.

- 3** Place **one portion** of the sample from one of the receptacles back **into the splitter** while placing the **other portion into container**.

8.2.

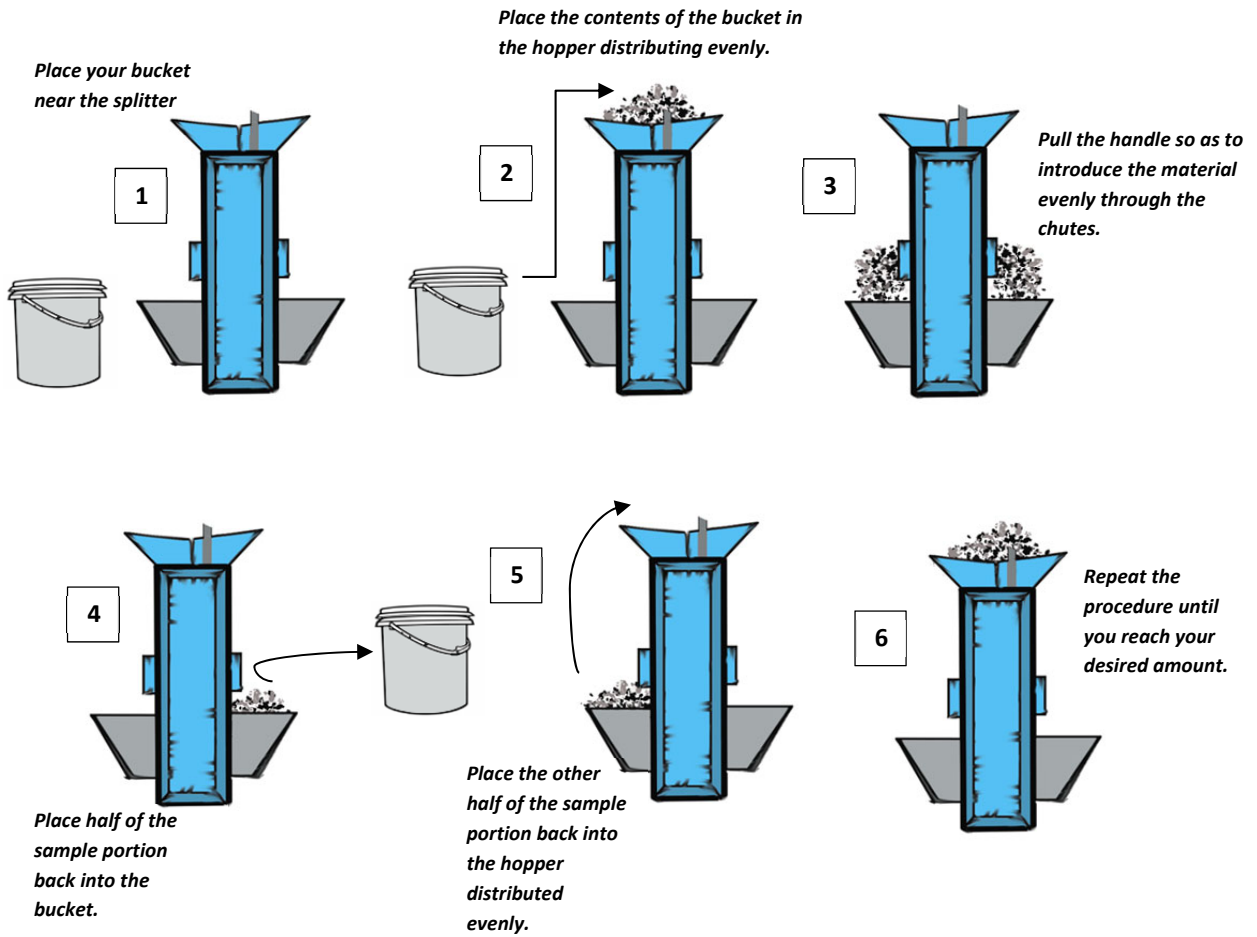

### METHOD B – QUARTERING:

#### EQUIPMENT:

9.

- STRAIGHT EDGE OR SHOVEL
- SPATULAS OR TROWELS
- BROOM OR BRUSH
- STICK OR PIPE
- TEAR RESISTANT RECTANGULAR TARP
- **QUARTERING TEMPLATE:** In the shape of 90° sides that exceed the diameter of the flattened cone of material. The height of the sides must be sufficient to extend above the thickness of the flattened cone of the sample.

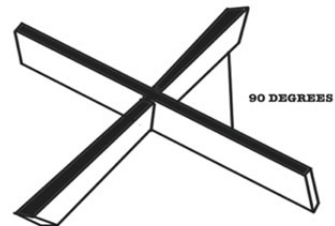

#### PROCEDURE:

10.1.1 Quartering on a Clean, Hard, Level Surface:

Stockpile on clean, hard, level surface.

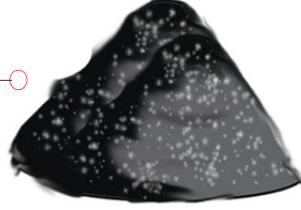

**1** Place the sample on a **clean, hard, level surface** where there will **NOT** be loss of material or contamination. 10.1.1.1.

Go around the perimeter turning the sample to mix and form a cone.

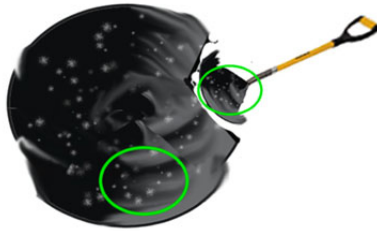

**2** Turn the **entire** sample over **three times** to mix the sample. On the **last turn** form the material into a **conical pile**. 10.1.1.2

Final pile



**3** Flatten the conical pile with your shovel to a **uniform thickness** and the **diameter** should be approximately **four to eight** times the thickness. 10.1.1.3

Flatten sample.

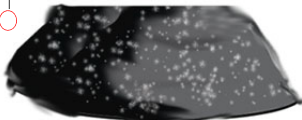

**4** Divide the flattened mass into approximately **four equal parts**. With: 10.1.1.4



Sample from diagonally opposite quarters.

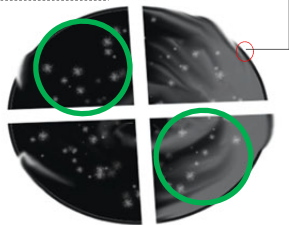

**5** Remove the **two diagonally opposite** quarters (including all the fine material using a brush). Set aside the unused quarters for later testing. Repeat the above steps until the **desired amount** is achieved. 10.1.1.5

### 10.1.3 Quartering Sectoring:

- 1** Place the sample on a surface.  
Refer to 10.1.3.

10.1.3.1

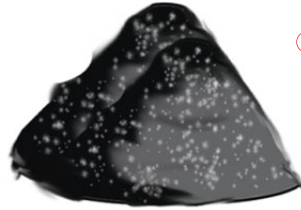

Stockpile on clean, hard, level surface.

Go around the perimeter turning the sample to mix and form a cone.

- 2** Turn the entire sample over **three times** to mix. On the last turn form the material into a conical pile. Refer to section 10.1.3.

10.1.3.2

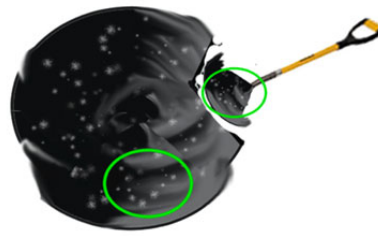

- 3** Flatten the conical pile.  
Refer to 10.1.3.

10.1.3.3

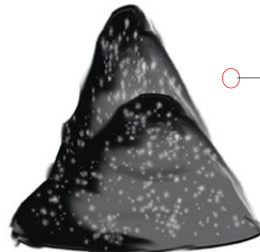

Final pile

- 4** Divide the flattened mass into approximately **four equal parts**. With:

10.1.3.4

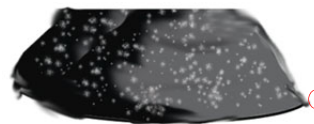

Flatten sample.

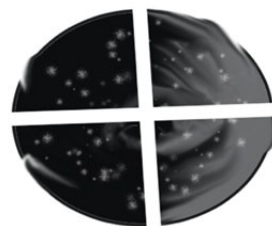

Divide into quarters.

- 5** Use a **straight edge** to slice through the center of one of the **quarters**. Achieve complete separation.

10.1.3.5

- 6 Remove approximately equal sectors from diagonally opposite quarters and combine. Repeat procedure until the required amount is obtained.

10.1.3.7

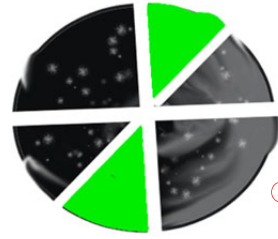

Divide the quarters in half and sample from opposite corners.

**METHOD C – MINATURE STOCKPILE SAMPLING:**

**EQUIPMENT:**

- STRAIGHT EDGE, FLAT BOTTOM SCOOP, SQUARE POINT SHOVEL, OR TROWEL.
- A SMALL SAMPLING THIEF, SMALL SCOOP, OR SPOON.

1.1.

**PROCEDURE:**

- 1 Place the sample on a clean, hard, level surface where there will NOT be loss of material or contamination.

12.1.

- 2 Turn the entire sample over three times to mix. On the last turn form the material into a conical pile or alternatively the pile can be flattened to a uniform thickness and diameter.

12.2.

- 3 Obtain a sample for each test by selecting at least 5 increments from random locations.

12.3

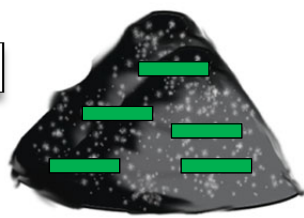

5 Random increments

**SECTIONS NOT COVERED:**

**10.1.2 Quartering on a Tarp:**

PLEASE REFER TO THE SECTION FOUND IN THE PROCEDURE FOR MORE DETAIL IF INTERESTED. THIS PROCEDURE IS NOT COVERED OR TESTED ON DURING ATTI CERTIFICATION.

10.1.2

# AASHTO R67: SAMPLING ASPHALT MIXTURES AFTER COMPACTION (CORES)

## DEFINITIONS:

**Cores** - is a reliable method for the extraction of representative samples from completed asphalt or concrete installations.

**Lift** - is a layer of asphalt pavement that is applied to a base or previous layer.



## SCOPE:

1.1.

*This standard covers the process for removal of core samples for laboratory testing. Core diameter range maybe from 2 inches to 12 inches.*

## EQUIPMENT:

4.

- **CORE DRILLING MACHINE**- Must be power driven and capable of obtaining a core to the full depth of the asphalt mixture. Have a rigid frame or platform so that the core barrel can be maintained perpendicular to the surface.
- **CORE DRILL BIT** -See manufacturers recommendation.
- **SEPARATION EQUIPMENT** – A saw or other method that provides a clean, layer to be tested without damage.
- **RETRIEVAL DEVICE**- A device that will remove the core without affecting the integrity of the sample.
- **COOLING AGENT** – Water, Ice, Dry Ice, or liquid nitrogen.
- **SAMPLE MARKING TOOL**
- **PACKAGE CONTAINERS**

## PROCEDURE:

*Coring asphalt is a common practice in the construction of roads and pavements. The process involves extracting a cylindrical sample (core) from an asphalt pavement using a core drill. This sample is then analyzed to assess the properties and condition of the pavement.*



**1** Position the core drilling machine over the **desired sampling location**. Begin the machine (along with the water or air) and advance slowly until it meets the asphalt surface. 5.3.

**2** Keep the machine **perpendicular to the surface** while applying constant pressure downward. 5.4.

**3** Continue **drilling to the bottom or slightly below** the asphalt mixture to allow full separation of the core sample from the underlying pavement. 5.4.2

**4** After drilling **separate the core sample from the underlying layers** using the **retrieval device** without damaging the sample. Brush off, or use water to wash off any loose particles on the sample. 5.6.

**5** **Clearly label** the core with the marking tool. 5.7.

**6** **Fill the hole** with asphalt mixture, non-shrink grout, or other suitable material. Compact the material in multiple lifts if necessary. Make sure the final surface is level with the surrounding surface. 5.8.

**Allow compacted asphalt mixtures to cool sufficiently prior to coring to avoid damage. To accelerate the process the area may be cooled with water, ice, dry ice, or liquid nitrogen.**

**EXAMPLE OF CORING MACHINE:**



**Open-Head**



**Closed-Head**



**EXAMPLE OF CORE BITS:**

**WHAT HAPPENS IF CONSTANT PRESSURE IS NOT APPLIED?**  
*If constant pressure is not applied then this may cause the core drill to bind or distort the core.*

## PACKAGING & TRANSPORT:



*When separating the layers Use appropriate equipment and do it along the designated lift line.*

- Place cores in suitable **protective containers**. If multiple cores must be placed in the same container, then separate from one another. 6.1.
- Transport samples so that they are **prevented** from damage from **jarring, rolling, or impact with any object**. 6.2.
- **Prevent** cores from **freezing** or from **excessive heat**. 6.3.
- If the core is **damaged** during transport the core **cannot be used for testing**. 6.4.



*In extreme ambient temperatures an insulated container should be used during transport.*

## IDENTIFICATION & SHIPPING (example)

### IDENTIFICATION & SHIPPING:

*Date*

*Paving Date*

*Coring Location*

*What Lift/ Layer*

*Average Thickness (if required)*

### **IF KNOWN:**

*Nominal Maximum Aggregate Size*

*Asphalt Mixture Design Info*

*Grade of Binder*



## PRACTICE QUESTIONS:

1. What is the minimum sample size for liquid asphalt & emulsions (according to AASHTO R66)?
  - a. 1 quart for liquid asphalt & 1 quart for emulsions.
  - b. 1 gallon for liquid asphalt & 1 quart for emulsions
  - c. 1 quart for liquid asphalt & 1 gallon for emulsions

*Go to section*
  
2. A Double-seal friction-top can is used to sample what type of material (according to AASHTO R66)?
  - a. Emulsions
  - b. Asphalt binder
  - c. Soils

*Go to section*
  
3. What kind of material does a technician use a wide mouth plastic jar to sample (according to AASHTO R66)?
  - a. Asphalt binder
  - b. Emulsions
  - c. Soils

*Go to section*
  
4. When sampling from a Windrow remove approximately \_\_\_\_\_ before taking your sample (according to AASHTO R97).
  - a. 2 feet
  - b. 1 foot
  - c. 3 feet

*Go to section*
  
5. What method is used to reduce fine aggregate (drier than SSD) (according to AASHTO R76)?
  - a. METHOD A – Mechanical Splitter
  - b. METHOD B – Quartering
  - c. METHOD C – Miniature Stockpile

*Go to section*
  
6. When transporting cores the technician has to protect them from \_\_\_\_\_ & excessive heat (according to AASHTO R67)?
  - a. Rain
  - b. Theft
  - c. Freezing

*Go to section*
  
7. When a front loader creates a flat pad to sample from how many random increments does the technician take to make up one sample (according to AASHTO R90)?
  - a. 3
  - b. 2
  - c. 1

*Go to section*

**ANSWERS:**

1. a
2. b
3. b
4. b
5. a
6. c
7. a



## ***In Place Density NON- Nuclear & Associated Procedures.***

*There are various tools utilized by the soil testing technician to determine the density of soil. In-place density testing provides essential data that ensures foundation stability, maintaining quality control, designing safe structures, and complying with specs. Non-Nuclear density testing is a very straight forward methodology and very effective in providing accurate measurements.*

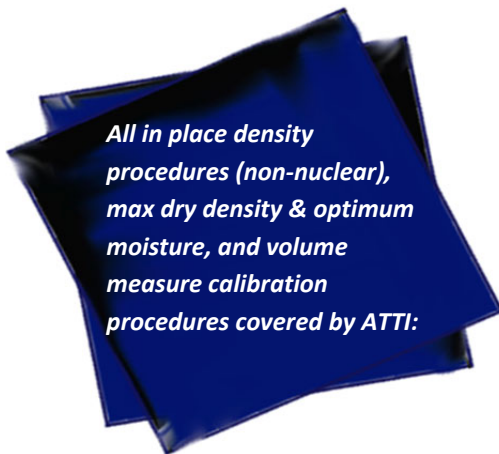

***All in place density procedures (non-nuclear), max dry density & optimum moisture, and volume measure calibration procedures covered by ATTI:***

- **AASHTO T191:** DENSITY OF SOIL IN-PLACE BY THE SAND CONE METHOD
- **AASHTO T217:** MOISTURE CONTENT BY CALCIUM CARBIDE METHOD
- **AASHTO T272:** ONE-POINT METHOD FOR DETERMINING MAXIMUM DRY DENSITY & OPTIMUM MOISTURE
- **ANNEX T99:** CORRECTION FOR MAX. DRY DENSITY & OPTIMUM MOISTURE CONTENT FOR OVERSIZED PARTICLES.
- **AASHTO T19 SECTION 8:** CALIBRATION OF MEASURE

**Learning objectives for these sections are:**

- 🌱 ***How to perform and calculate in place density and moisture.***
- 🌱 ***How to properly calibrate a volume measure.***
- 🌱 ***How to determine max dry density and optimum moisture along with graphing.***
- 🌱 ***How to correct max dry density and optimum moisture if the sample contains oversized particles.***
- 🌱 ***Learn the basic terminology for density determination.***



**PLEASE REFER TO THE SECTION FOUND IN THE PROCEDURE FOR MORE DETAIL. THE SECTION NUMBER WILL BE PROVIDED FOR REFERENCE.**



# AASHTO T191:

## DENSITY OF SOIL IN-PLACE BY THE SAND-CONE METHOD

### DEFINITIONS:

**In-Place Dry Density-** is a measure of how compact a material is, and is calculated by comparing its weight to the volume of space it occupies.

**Volume** – a measure of a region within 3-dimensional space.

**Dry Mass** – the weight of the material after the water content has been removed.



### SCOPE:

1.1

*This standard is the method of determining the in-place density of soil using the sand cone method.*

### EQUIPMENT:

3.1.

- **DENSITY APPARATUS WITH BASE PLATE-** Consists of 1 gallon jar and detachable gadget that consists of a cylindrical valve with a hole ½" in diameter and a small funnel on one end and a larger one on the other. The smaller funnel is to be attached to the jar.
- **CALIBRATION CONTAINER** – a cylindrical container with a known volume.
- **SAND** – any clean dry free-flowing uncemented sand. Very few of the particles can pass the #200 (0.075 mm) or can be retained on the #10 (2.00 mm) screen.
- **BALANCES / SCALES** - that has the capability to weigh out to the 0.01 lb.
- **EQUIPMENT** – small pick, chisels, spoons, buckets with lids, brushes, something to measure with.

### CONE CORRECTION:

*The cone correction is, a factor for the sand used to fill the cone and the hole recess of the plate. If this displacement is not accounted for, the calculation of the in-place density would be too high, leading to inaccurate test results. This ensures that the volume of sand actually used to fill the hole (and not the apparatus) is accurately measured.*

- **Fill** the apparatus with dried **sand**. The apparatus can be filled either with the **funnel on or off**. Make sure the sand is dried and conditioned to a similar state as it will be during testing.

4.1.1

- **Weigh** the apparatus filled with sand. Record the weight to the **0.01 lbs.** Record this weight as *M1* to follow the AASHTO example.

4.1.2

- Place the base plate on clean level surface. Invert the sand cone filled with sand and **seat the funnel in the recess of the base plate.**

4.2.1

- Open the valve fully and allow the sand to **flow until it stops.**

4.2.2

- **Close the valve** sharply and fully, remove the apparatus and **weigh** with the remaining sand in the device. Record this weight as *M2* to follow the AASHTO example.

4.2.3



**CONE CORRECTION CALCULATION:**

$$C_c = M_1 - M_2$$

$C_c$  = cone correction;

$M_1$  = Weight of apparatus filled with sand;

$M_2$  = Weight of apparatus after opening the valve and flow have ceased;

**BULK DENSITY SAND:**

*The bulk density of sand factor (also called the sand factor) is a calibration factor used in the sand cone test to convert the weight of the sand (used to fill the hole) into a volume measurement.*

- Replace the sand used during the cone correction procedure. Close the valve and **weigh and record to 0.01lb.** Record this weight as *M3* to follow the AASHTO calculation.

4.3.1

- Place the calibration container on clean level surface. Place the **base plate on the calibration container.** Invert the sand cone filled with sand and seat the funnel in the recess of the base plate.

4.3.2



*Each container/bag of sand will have a unique cone correction and sand calibration factor. Each sand cone and base plate should be marked and associated with the correction / density factors.*

- **Open the valve fully** and allow the sand to flow until it stops. 4.3.3.
- Once stopped close the valve completely, remove from the base plate and **weigh to 0.01lb**. Record the weight as *M4* to follow the AASHTO calculation. 4.3.4
- Subtract *M3*, *M4*, and *Cc* (Cone Correction). Repeat the above steps and do this **calculation three times and average**. Take this number and **divide by the known volume** of the container. Record your answer to **0.1 lb/ft<sup>3</sup>**. 4.3.5.

**DENSITY OF SAND CALIBRATION FACTOR:**

$$Db = \frac{(M3 - M4 - Cc)}{Vc}$$

**Db = Sand calibration factor;**

**M3 =** Weight of apparatus filled with sand;

**M4 =** Weight of apparatus after opening the valve and flow have ceased;

**Cc =** Cone correction;

Example

$$\begin{array}{r} M3 - M4 - Cc = x \\ M3 - M4 - Cc = y \\ M3 - M4 - Cc = z \end{array} \quad \frac{x + y + z}{3} = m \quad \frac{m}{Vc} = Db$$

**Vc = volume of the calibration container.**

**PROCEDURE:**

- 1** Fill the apparatus with dried sand. Weigh the apparatus filled with sand and record to **0.01lb** Record as *M5* to follow the AASHTO calculation. 5.1.1
- 2** Prepare the testing location so that it is **level and plane**. 5.1.2
- 3** Seat the base plate on the prepared surface. Dig the test hole inside the opening of the base plate. Place all loosened soil in container with top so not to lose moisture. 5.1.3.
- 4** Place the apparatus on the base plate and open the valve. Close sharply after the sand has stopped flowing. 5.1.4





**5** Weigh the apparatus with the remaining sand and **record to 0.01/lb.** Record as *M6* to follow the AASHTO calculation.

5.1.5

**6** Record the volume of the test hole to the nearest **0.0001 ft<sup>3</sup>**

5.1.5



**WHAT IS THE VOLUME OF THE TEST HOLE WITH THE FOLLOWING VARIABLES?**

Cone Correction: 3.26lbs  
 Density of Sand: 81.1lbs/ft<sup>3</sup>  
 M5: 14.59lbs  
 M6: 6.35lbs

**ANSWER: 0.0614 ft<sup>3</sup>**

**VOLUME OF TEST HOLE:**

$$V_h = \frac{(M5 - M6 - Cc)}{D_b}$$

**D<sub>b</sub>** = Density of Sand calibration factor;

**M5** = Weight of apparatus filled with sand;

**M6** = Weight of apparatus after opening the valve and flow has ceased;

**C<sub>c</sub>** = Cone correction;

**V<sub>h</sub>** = Volume of the test hole;

**Moisture**

**7** Weigh the material that was removed from the test hole.

5.1.6.

**8** Mix the material and weigh out a representative sample that is appropriate to the particular moisture content drying procedure that the technician will use.

5.1.7

**9** Dry & weigh the sample according to:

5.1.8.

AASHTO 265: Moisture Content of Soils

OR

AASHTO T217: Speedy Moisture Determination

OR

AASHTO T255: Moisture Content of Aggregates

**i** Get the tare weight of the container so that the entire sample can be easily weighed.

**Calculate the moisture content to the nearest 0.1 % & the DRY MASS OF THE MATERIAL to the nearest 0.01lb.**

**DRY MASS OF THE MATERIAL:**

$$Mds = \frac{(Mws)}{\left(1 + \left(\frac{w}{100}\right)\right)}$$

Mds = dry mass of the material removed from the test hole.

Mws = wet mass of the material removed from the test hole.

w = percentage of moisture in material removed from test hole.

**In-Place Dry Density Calculation**

**IN-PLACE DRY DENSITY:**

$$Dd = \frac{(Mds)}{(Vh)}$$

**Calculate the in-place density to the nearest 0.1 lb/ft<sup>3</sup>**

Dd = in-place dry density of the material removed from the test hole.

Mds = dry mass of the material removed from the test hole.

Vh = volume of the test hole.

**WHAT IS THE IN-PLACE DRY DENSITY WITH THE FOLLOWING VARIABLES?**

Volume of the Hole: 0.0614 ft<sup>3</sup>  
MDS: 7.25lbs

**ANSWER: 118.1 lbs/ft<sup>3</sup>**

# AASHTO T217: DETERMINATION OF MOISTURE IN SOILS BY MEANS OF A CALCIUM CARBIDE GAS PRESSURE MOISTURE TESTER.

**DEFINITIONS:**

**Moisture Content by Wet Mass** – is the amount of water per unit mass of a wet material.

**Moisture Content by Dry Mass** – is the amount of water per unit mass of dry material. This is what the technician is trying to convert to.



## SCOPE: 1.1.

*This test method covers determining the moisture content of soils by means of a calcium carbide gas pressure moisture tester. Follow manufacturer's instructions for proper use of the equipment.*

## EQUIPMENT: 3.

- **CALCIUM CARBIDE PRESSURE MOISTURE TESTER** - A chamber with an attached pressure gauge for the water content of specimens having a mass of at least 20g.
- **BALANCE** – That is accurate to the nearest gram.
- **STEEL BALLS** – Two 31.75 mm (1.25inch) steel balls.
- **CLEANING BRUSH & CLOTH**
- **SCOOP** – for measuring out calcium carbide.



- **CALCIUM CARBIDE REAGENT** – must be finely pulverized and should be a grade capable of producing acetylene gas in the amount according to the procedure. Material has a shelf life and must be checked periodically.

## PROCEDURE:

*The speedy moisture tester quickly and accurately determines the wet mass moisture content of soils (or granular materials). Then with the correction curve the technician can determine the dry mass moisture content of the sample.*

- 1** When using the **20 or 26 g** tester, place **3 scoops** of calcium carbide in the cap of the tester.

5.1.



2

Weigh out a **20-gram** sample (or the exact mass per manufacturer instructions). Place that sample into the **body** of the tester.

5.2.

**Make sure that NO water comes into contact with the calcium carbide.**

3

Make sure the tester is **horizontal** then place **two 1.25" steel balls** into the **body** of the tester.

5.2.



EXAMPLE SPEEDIE MOISTURE TESTER & CAP



EITHER:

3 Scoops of calcium carbide reagent in the cap & Soil Sample (20grams) in the body of the moisture tester.

OR

3 Scoops of calcium carbide reagent in the body of the moisture tester & Soil Sample (20grams) in the cap.

4

While still in a **horizontal** position insert the cap and **tighten the clamp**.

5.3.



5

Then turn the tester to the **vertical** position so both the **soil and the calcium carbide** can come into contact.

5.4.



6

**Shake vigorously** in a **rotating** motion while in a horizontal position. At least **60 sec** for granular soils and **180 sec** for other types of soil.

5.5.

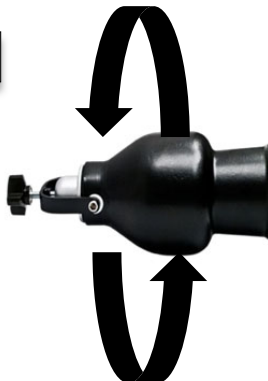

**7** Set down on the table horizontally to let the heat dissipate. Once the needle stops moving read the dial at eye level.

5.6.

Example Speedie Moisture Tester

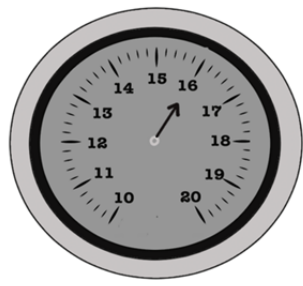

**8** Record both the sample mass and the dial reading.

5.7.

**i** Make sure the tester is thoroughly cleaned of all carbide residue before running another test.

**9** Point the tester away (normally there is a vent make sure to point the vent down and away) and release the cap slowly. Empty the sample into a container and examine for lumps. If not fully pulverized redo the test.

5.8.

**10** Convert Wet Mass from the dial to Dry Mass with a correction curve. An example of a graph used.

6.

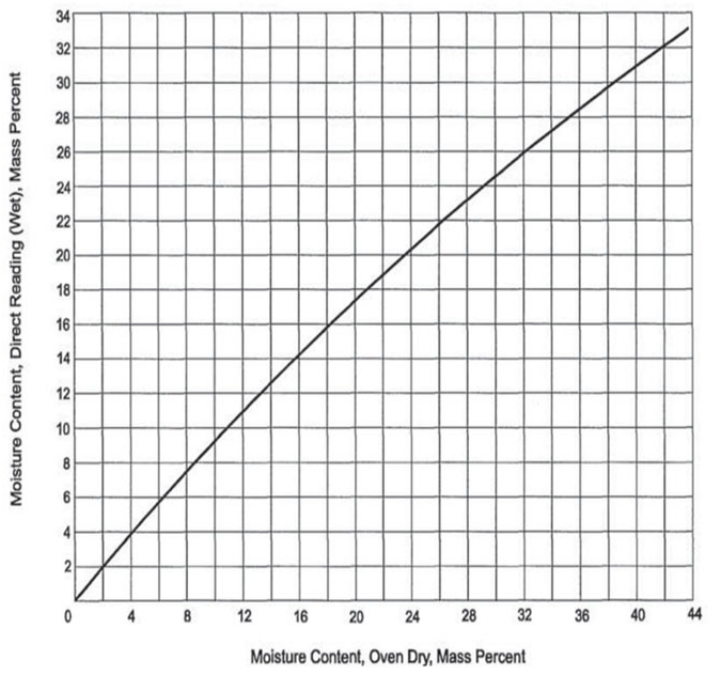

# AASHTO T272:

## ONE-POINT METHOD FOR DETERMINING MAX DRY DENSITY & OPTIMUM MOISTURE

**DEFINITIONS:**

**Max Dry Density** - is the highest dry density that a soil or aggregate can reach.

**Optimum Moisture** – is the percent of moisture at which the greatest density a soil can be obtained through compaction.

**Compaction** - is the process of pressing soil particles together to reduce the space between them, which increases the soil's density.

**Friable** – is easily crumbled.

### SCOPE: 1.1.

*This procedure covers how to rapidly determine the maximum dry density and optimum moisture content of soil with one point.*

### EQUIPMENT: T99: 3.

- **MOLD & ASSEMBLY (Mold, Collar, and Base Plate)**- See procedure for precise dimensions.
- **RAMMER:** Either Manual or Mechanical
- **SAMPLE EXTRUDER**
- **BALANCE / SCALE**
- **DRYING OVEN** – Thermostatically controlled capable of maintaining temperature of 230 +-9 degrees F.
- **STRAIGHT EDGE**- at least 10 inches in length.
- **SIEVES** – 3/4" and #4.
- **MIXING TOOLS** – spatulas, spoons, .... etc.
- **CONTAINERS** – Containers capable to handle constant heating and cooling and resistant to corrosion.
- **PACKAGE CONTAINERS**

### METHOD:

 **Soil that has 40 % or less retained on #4 will be Method A OR Method B.**

**Soil that has 30 % or less retained on 3/4" will be Method C OR Method D.**

- The **One Point determination (T272)** is made by compacting soil using the **AASHTO T99** procedure: 4.2.
  - **Method A** – using a 4-inch mold: soil passing #4 screen.
  - **Method B** – using a 6-inch mold: soil passing #4 screen.
  - **Method C** – using a 4-inch mold: soil passing  $\frac{3}{4}$ " screen.
  - **Method D** – using a 6-inch mold: soil passing  $\frac{3}{4}$ " screen.
  
- The One Point determination method **must match** the individual moisture/density curves or family of curves developed in the lab. **Method's must be the same!** 4.3.
  
- Obtain your representative sample making sure that it is between **80 to 100% optimum moisture**. Adjust the moisture content if necessary. 7.1.

## AASHTO T272 / AASHTO T99: METHOD A

### SAMPLE:

- **Obtain representative sample** according to test procedure. 6.1.
  
- If the sample from the field is **greater than Optimum** follow **drying** procedure from **AASHTO T99**. 6.1.1
  
- Sieve the sample over a **#4 screen**. When the sample has oversized material refer to **ANNEX A1**. T99: 4.3.

### PROCEDURE:

**Maximum Dry Density (MDD)** "Max dry density" refers to the highest possible density a type of soil can achieve when compacted at its optimum moisture content or in other words the maximum amount of dry soil mass that can fit within a given volume, indicating the point where further compaction will not increase density.

**Optimum Moisture Content (OMC)** is the moisture level at which this densest state is achieved.

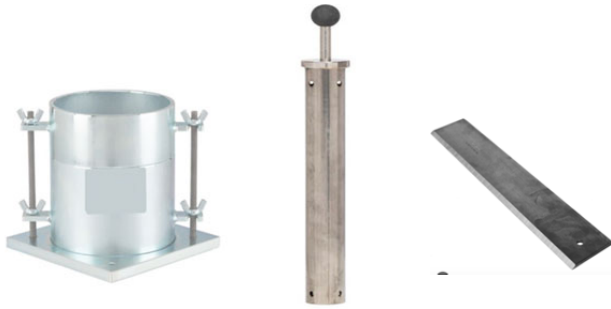

*If the material is free draining soils such as uniform sands and gravels where seepage occurs at the bottom of the mold. Take a representative moisture content sample from the mixing bowl*

**1** Weigh the mold and the baseplate to the nearest **0.005lbs**. Do Not include the collar in the weight.

T99: 5.1.

**2** Thoroughly **mix** the representative sample, make sure that the sample it is between **80% to 100% of optimum moisture**. Adjust the moisture if necessary to place the sample in this

8.2.1



**3** Form a specimen by compacting soil in **4-inch mold in 3 approximately equal layers**.

T99: 5.3.

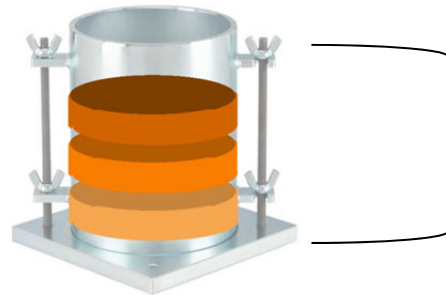

3 Layers

**4** The total **compacted depth** of the specimen will be **approximately 5 inches**.

T99: 5.3.

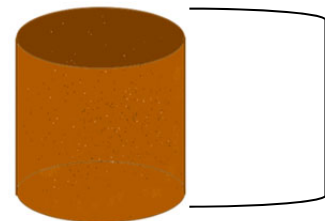

5-inches

**5** Place the loose soil into the mold and spread into a **uniform layer distributed evenly** in the mold. Make sure to **tamp the loose material down before compaction**.

T99: 5.3.

**6** Using the rammer compact **each layer** with **25 evenly distributed blows** from a **12-inch height**. After the compaction of the first two layers, **make sure to trim off any material along the mold wall that isn't compacted and redistribute along the surface**.

T99: 5.3.



**7** After all, **3 layers** are **compacted** completely remove the collar and trim the soil even with the top of the mold.

T99: 5.3.1.



8 Determine the **mass** of the **mold, base plate, and sample** to the nearest **0.005/lb.** T99: 5.3.1.

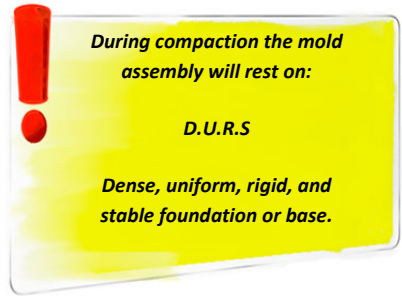

9 Now Calculate the **wet density** by the T99 calculation. T99: 5.3.1.

**WET DENSITY CALCULATION:**

$$Pt = \frac{(A-B)}{(V)}$$

Pt = wet density of compacted soil in *lb/ft<sup>3</sup>*;

A = Mass of the mold, base plate, and wet soil;

B = Mass of the mold, base plate;

V = Volume of the mold;

**MOISTURE CONTENT**

10 **Remove** the base plate and the material using an extruder or, if using a split **mold**, unscrew the wing nut so the mold can open and release the **sample**. T99: 5.4.

11 Obtain a representative sample of the material by slicing **vertically** through the center of the molded material and **remove the face of the cut** or from the center of the pile. (*If material falls apart*). T99: 5.4.

12 Determine the **moisture content** using one of the following methods: 7.4.

**RED AREA IS WHERE YOU ARE TO TAKE MOISTURE CONTENT SAMPLE FROM.**

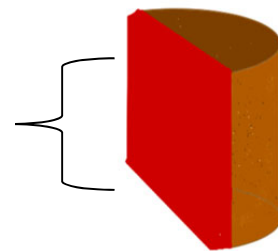

**AASHTO 217**

**AASHTO T265**

**AASHTO T255**

**CALCULATION OF MOISTURE CONTENT  
(T265):**

$$W = \left[ \frac{(W_1 - W_2)}{(W_2 - W_c)} \right] \times 100$$

**W** = Moisture content in percent.

**W1** = Mass of the container and sample in grams.

**W2** = Mass of the container and oven-dried sample in grams.

**Wc** = Mass of the container in grams.

**DRY DENSITY CALCULATION**

**DRY DENSITY CALCULATION:**

$$P_d = \left[ \frac{P_t}{(W+100)} \right] \times 100$$

**W** = Moisture content in percent of specimen.

**Pt** = Wet density of compacted soil in  $lb/ft^3$ ;

**Pd** = Dry density of compacted soil in  $lb/ft^3$ ;

DIFFERENCES BETWEEN METHODS (AASHTO T272/ T99):

METHOD A:

- (After oversized material has been removed) Minimum 7lbs - *may be adjusted for one-point determination.*
- Sieved over #4 screen.
- 4 inch Mold.
- 25 Uniformly Distributed Blows.

T99: 4.

METHOD B:

- (After oversized material has been removed) Minimum 16lbs - *may be adjusted for one-point determination.*
- Sieved over #4 screen.
- 6 inch Mold.
- 56 Uniformly Distributed Blows.

T99: 6.

METHOD C:

- (After oversized material has been removed) Minimum 11lbs - *may be adjusted for one-point determination.*
- Sieved over 3/4" screen.
- 4 inch Mold.
- 25 Uniformly Distributed Blows.

T99: 8.

METHOD D:

- (After oversized material has been removed) Minimum 25lbs - *may be adjusted for one-point determination.*
- Sieved over 3/4" screen.
- 6 inch Mold.
- 56 Uniformly Distributed Blows.

T99: 10.

ONE POINT DETERMINATION:

INDIVIDUAL MOISTURE/ DENSITY CURVE:

- **Moisture content** must be **within 80 to 100 percent** of the **optimum moisture** of the reference curve. If the one point **does not** land in this range, then **compact another** specimen using the same material with an **adjusted moisture** content. 8.2.1
- Plot the one-point **moisture content** as the **X coordinate** and the **dry density** as the **Y coordinate**. 8.2.2

**!** Perform a full moisture / density relationship with the lab if the on-point determination does not meet the requirements.

- Use the **maximum dry density and optimum moisture content** defined by the **reference curve** if the one-point dry density and moisture content falls on the curve or **within ± 2.0 lb/ft<sup>3</sup>** of it. 8.2.3

## REFERENCE GRAPH

- Below is an example of a reference curve that was completed by the lab.

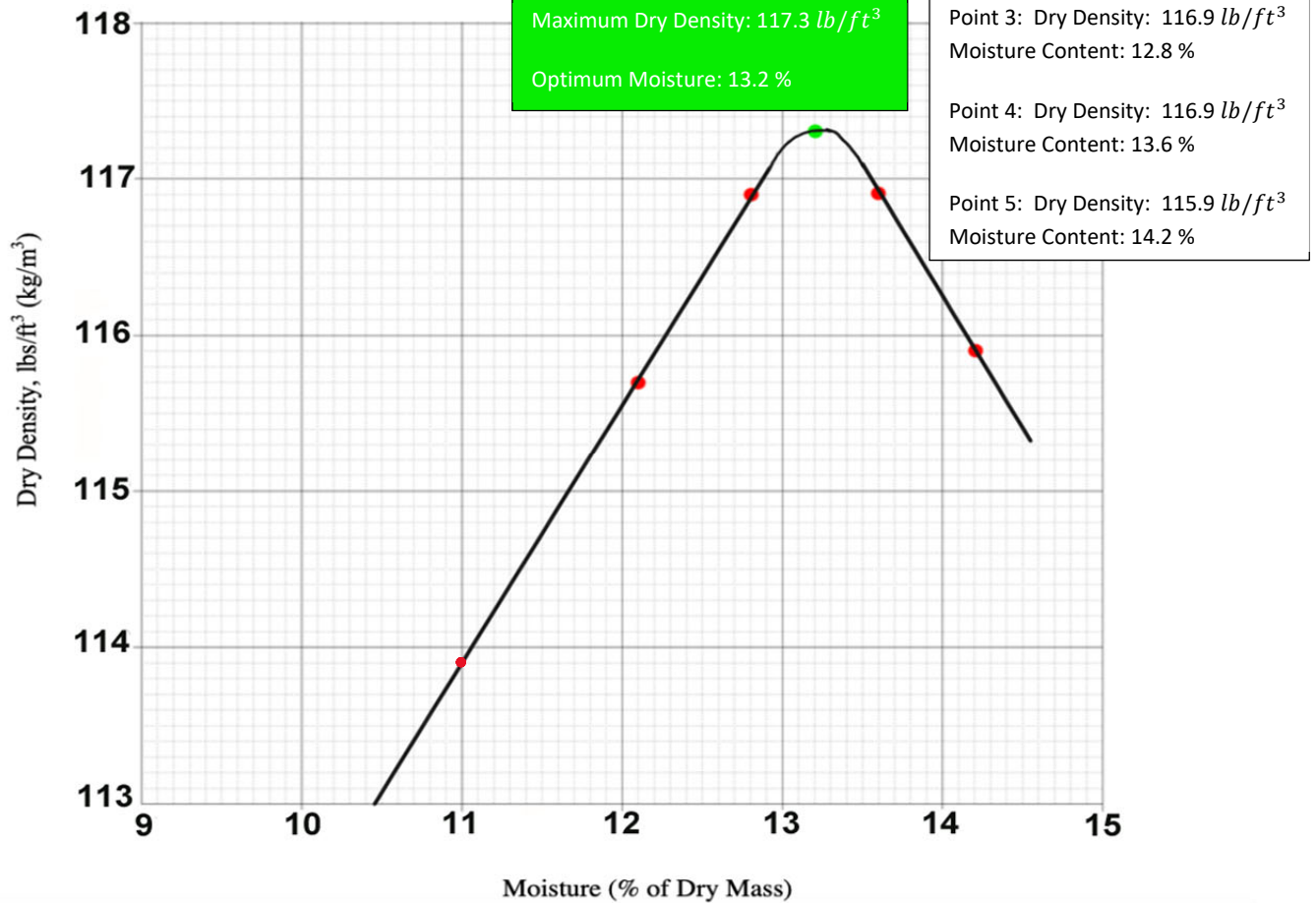

## PLOTTING 80% OPTIMUM MOISTURE

- Calculate 80% of Optimum Moisture  
 $13.2 * 0.8 = 10.6\%$   
Then Graph.

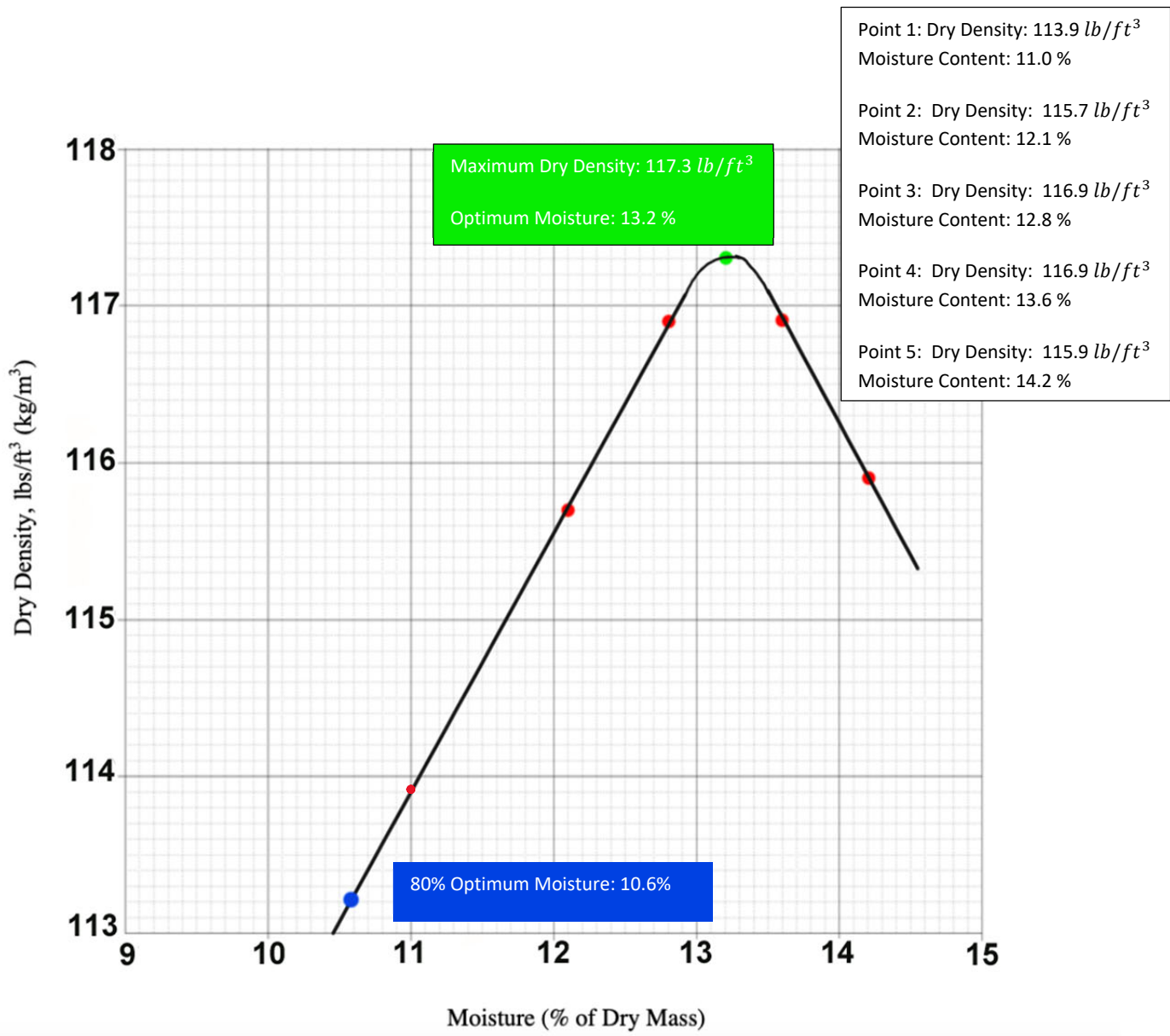

Which technician met all the requirements for this procedure?

**TECHNICIAN 1:** Dry Density: 117.8 lb/ft<sup>3</sup>  
Moisture Content: 11.0 %

**TECHNICIAN 2:** Dry Density: 115.9 lb/ft<sup>3</sup>  
Moisture Content: 12.5 %

**TECHNICIAN 3:** Dry Density: 113.2 lb/ft<sup>3</sup>  
Moisture Content: 9.3 %

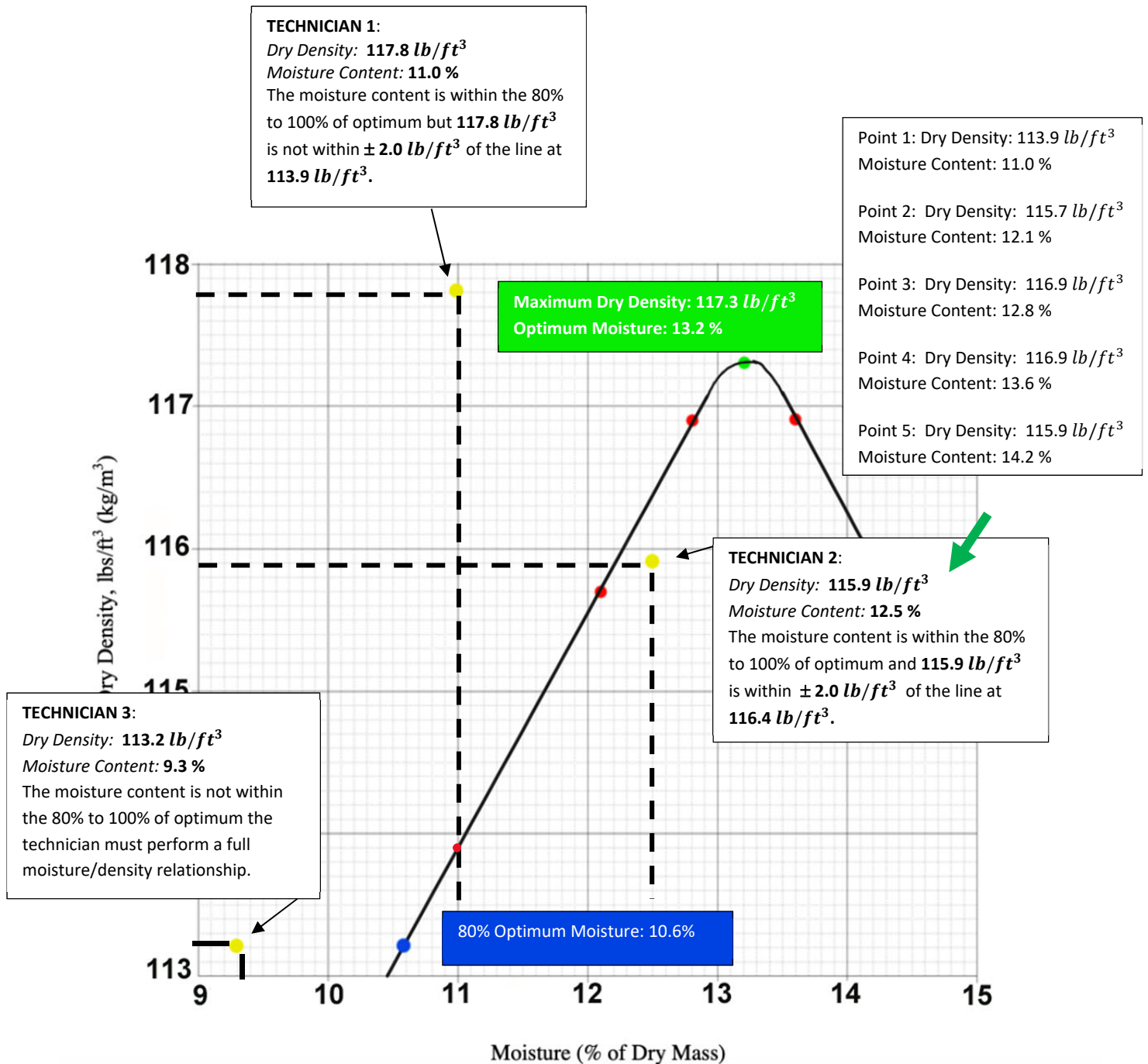

- Perform a full moisture/density relationship in the lab if the one-point determination does not meet the above stated requirements.

8.2.3.1.

- When oversized particles have been removed use T99 ANNEX A1 to determine the corrected maximum dry density and optimum moisture content.

8.2.4.

**FAMILY OF CURVES:**

**!** *Either develop a Family of curves according to R75 or use one already developed that is applicable to your state.*

- Plot the one-point moisture content as the X coordinate and the dry density as the Y coordinate. 8.3.1
- If the one point does not fall directly on one of the Family of Curves draw a new curve through the plotted one-point parallel and close to the shape of the nearest existing curve. 8.3.3.
- Find the Maximum Dry Density and Optimum Moisture content of the new curve finding the point that intersects with the developed Family of Curves Max Density Line. 8.3.4.

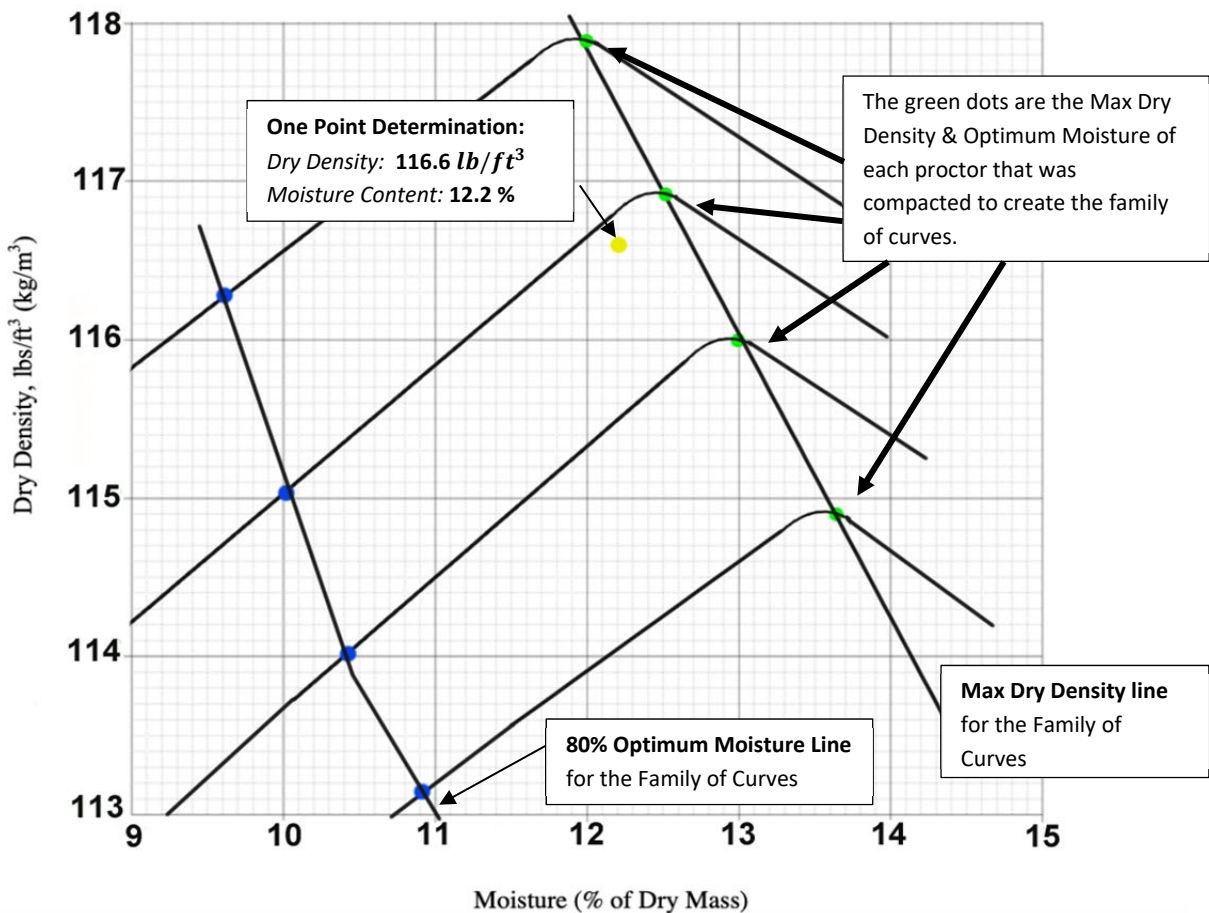

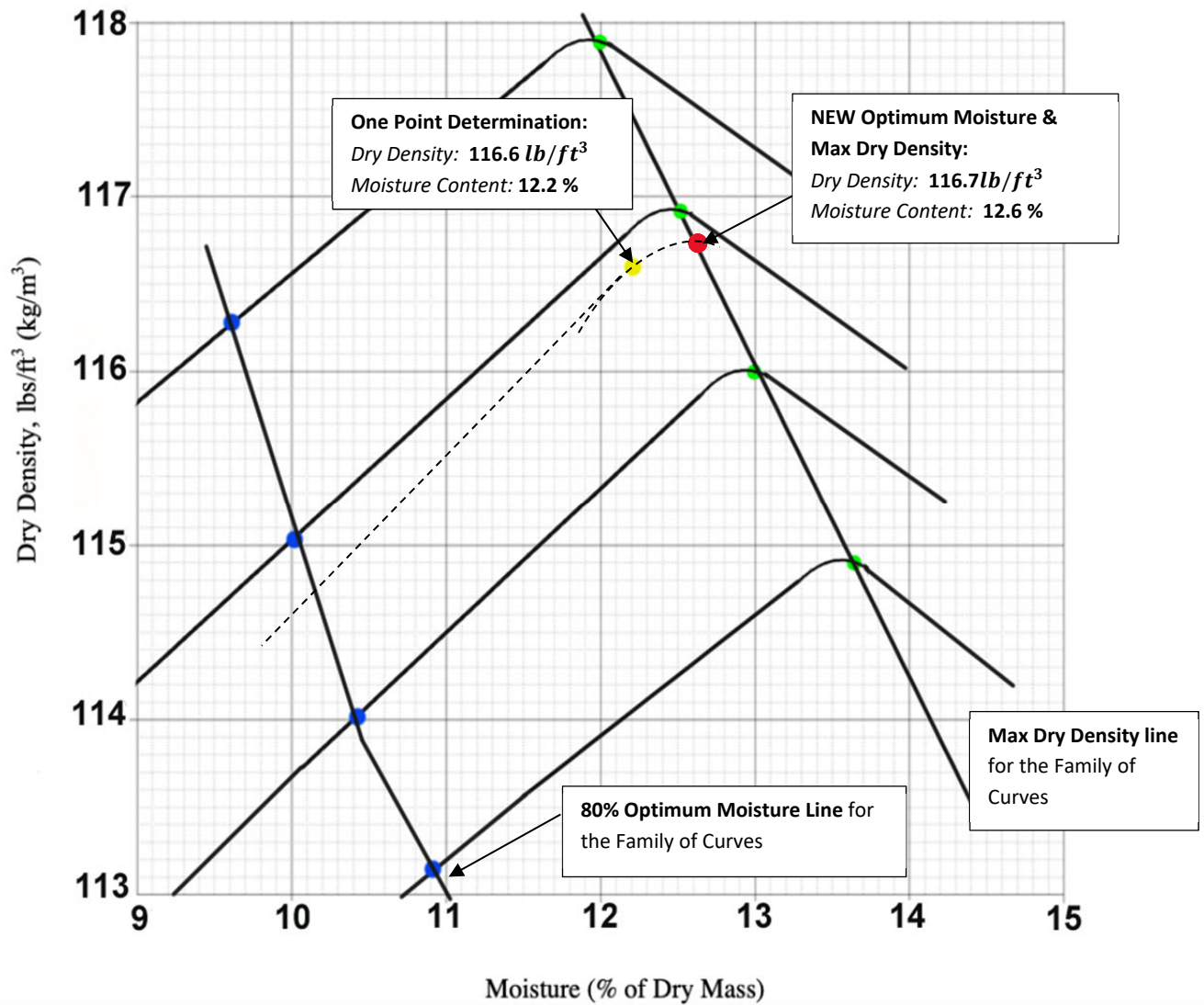

- If the One Point Determination falls **DIRECTLY** on a curve, then utilize the **Max Density and Optimum Moisture** from that curve.
- When oversized particles have been removed use **T99 ANNEX A1** to determine the **CORRECTED maximum dry density and CORRECTED optimum moisture content**.
- Perform a full moisture/density relationship in the lab if the one-point determination does not fall within the family of curves or meets the 80 to 100 percent within optimum moisture.

8.3.2.

8.3.4.1.

8.3.5.



**AASHTO ANNEX T99:  
CORRECTION FOR MAX. DRY  
DENSITY & OPTIMUM  
MOISTURE CONTENT FOR  
OVERSIZED PARTICLES.**

**SCOPE:**

A1.1.

*This section corrects the max dry density & optimum moisture of material retained on #4 screen (Method A & Method B) or the material retained on 3/4" screen (Method C & Method D).*

**PROCEDURE:**

- You can apply this correction to the field max dry density and field optimum moisture content procedure.

A1.1.1.

**AND/OR**

In-place density procedures in the field.

A1.1.2.

- If **obtaining your sample according to T310 Section 9.6**. Sieve the sample over the appropriate sieve. If not drying the entire sample, then use the calculation for Dry Mass (A1.3.2.1).

A1.1.2.

- Bulk Specific Gravity** of the oversized particles is required to determine the corrected Maximum dry density. Use T85 for this, although assumed coarse specific gravities for construction projects are generally 2.600.

A1.2.

- Determine the **dry mass of the coarse & fine material** from the sample by the calculation for Dry Mass (A1.3.2.1).

A1.3.

**OR**

The technician can dry both portions in air or in an oven that does not exceed 140 °F.

- Determine the **moisture content by T265, T255, or T217**. (If the moisture content is generally known for the coarse material you can substitute this into the equation.)

A1.3.2.

**If there is no minimum specified to the technician then correction will be applied to samples with more than 5 % by weight of oversized particles.**

**Example:**

Lab Proctor: **112.9 lb/ft<sup>3</sup> @ 11.1 % Optimum moisture content.**

Amount of Wet Fine Material: **22.410 lbs.**

Amount of Wet Coarse Material: **7.850 lbs.**

Gsb: **2.562**

Moisture Content Coarse: **2.0%**

Moisture Content Fine: **10.6%**

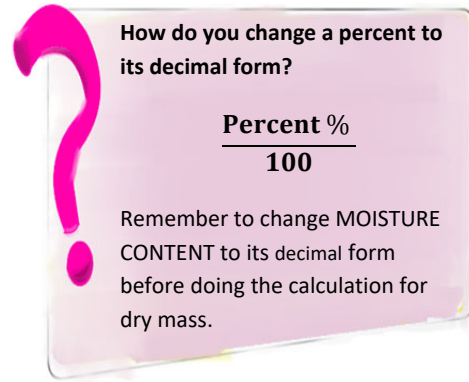

**CALCULATION FOR DRY MASS OF OVERSIZED & FINE PARTICLES**

$$MD = \frac{MM}{(1+MC)}$$

MD = mass of dry material (fine or oversized particles);

MM = mass of wet material (fine or oversized particles);

MC = moisture content of respective fine or oversized particles (decimal);

**CALCULATION FOR DRY MASS OF OVERSIZED & FINE PARTICLES**

$$MD = \frac{7.850 \text{ lb}}{(1+0.020)}$$

ANSWER:

**MDC = 7.696 lb.** (Dry mass of coarse particles)

$$MD = \frac{22.410 \text{ lb}}{(1+0.106)}$$

ANSWER:

**MDF = 20.262 lb.** (Dry mass of fine particles)

**CALCULATION FOR THE PERCENTAGE OF OVERSIZED & FINE PARTICLES:**

$$PF = \frac{(100 * MDF)}{(MDF + MDC)}$$

$$PC = \frac{(100 * MDC)}{(MDF + MDC)}$$

PF = Percent of dry fine particles;

PC = percent of oversized particles of sieve used;

MDF = mass of dry fine particles;

MDC = mass of dry oversized particles (decimal);

**CALCULATION FOR THE PERCENTAGE OF OVERSIZED & FINE PARTICLES**

$$PF = \frac{(100 * 20.262 \text{ lb})}{(20.262 \text{ lb} + 7.696 \text{ lb})}$$

ANSWER:

**PF = 72%.**

$$PC = \frac{(100 * 7.696 \text{ lb})}{(20.262 \text{ lb} + 7.696 \text{ lb})}$$

ANSWER:

**PC = 28%**

**CALCULATION FOR THE CORRECTED OPTIMUM MOISTURE:**

$$MCT = \frac{(MCF * PF) + (MCC * PC)}{100}$$

**MCT** = corrected optimum moisture content of the total sample, as a decimal;

**MCF** = optimum moisture content of the fine particles, as a decimal;

**PF** = percent of fine particles of sieve used;

**PC** = percent of oversized particles of sieve used;

**MCC** = moisture content of the oversized particles, as a decimal;

**CALCULATION FOR THE CORRECTED DRY DENSITY:**

$$DD = \frac{(100 * DF * k)}{(DF * PC + k * PF)}$$

**DD** = corrected maximum dry density of the total sample ( $lb/ft^3$ );

**DF** = maximum dry density of the fine particles, ( $lb/ft^3$ );

**k** = 62.4 X Bulk Specific Gravity (oven dry basis) of coarse particles ( $lb/ft^3$ );

**PC** = percent of oversized particles of sieve used;

**PF** = percent of fine particles of sieve used;

**CALCULATION FOR THE CORRECTED OPTIMUM MOISTURE:**

$$MCT = \frac{(11.1\% * 72\%) + (2.0\% * 28\%)}{100}$$

**ANSWER:**

**MCT = 8.6 %**

**CALCULATION FOR THE CORRECTED DRY DENSITY:**

$$DD = \frac{(100 * 112.9lb/ft^3 * 159.9lb/ft^3)}{(112.9lb/ft^3 * 28\%) + (159.9lb/ft^3 * 72\%)}$$

**ANSWER:**

**DD = 123.0 lb/ft<sup>3</sup>**

## AASHTO T19 SECTION 8: CALIBRATION OF MEASURE

### SCOPE:

1.1.

Section 8 of this standard covers the determination of the volume of a measure. This procedure is referenced in **AASHTO T272: ONE-POINT METHOD FOR DETERMINING MAX DRY DENSITY & OPTIMUM MOISTURE** & **AASHTO T191: DENSITY OF SOIL IN-PLACE BY THE SAND-CONE METHOD**.

Examples of Measures Utilized in Field Procedures:



### EQUIPMENT:

5.

- **BALANCE**- That is readable to 0.1/lb.
- **MEASURE** – A cylindrical container made of steel or another suitable material.
- **PLATE GLASS** – A piece of glass at least ¼” and at least 1 inch larger than the diameter of the measure.
- **GREASE**- A grease that is normally used for water pumps, chassis, or similar.
- **THERMOMETER**- Having a range of at least 50°F to 90°F with an accuracy of ±0.9°F.

### FREQUENCY:

- Determine the **volume of the measure** when initially obtained and at a frequency not to **exceed 12 months** or whenever there is reason to question the accuracy. Retain the calibration record in accordance of R18.

8.1.

### PROCEDURE:

**If calibrating the 6” proctor mold, apply the grease in a way to create a water proof seal. All other steps are the same as below.**

- 8.2. First place a thin layer of grease on the rim of the measure.

1



- 8.4. Cover the measure with the plate glass in a way so as not to have air bubbles and excess water.

4

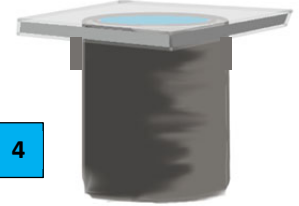

- 8.3. Determine the mass of the Glass Plate AND Determine the mass of the Measure (with grease on it) to the nearest 0.1lb or refer to your agency's procedure.

2



- 8.5. Determine the mass of the water, glass plate, and water to the nearest 0.1lb or your agencies procedure.

5



- 8.4. Fill the measure with water that is room temperature.

3



- 8.6. Measure the temperature of the water to the nearest 1°F.

6



- Density of Water Table: interpolate if necessary.

**CALCULATION OF VOLUME:**

$$V = \frac{(B-C)}{(D)}$$

V = Volume of the measure (ft<sup>3</sup>);

B = Mass of the water, glass plate, and measure, (lb.);

C = Mass of the glass plate, and measure, (lb.);

D = Density of the water for the measure, (lb/ft<sup>3</sup>);

°C	°F	kg/m <sup>3</sup>	lb/ft <sup>3</sup>
15.6	60	999.01	62.366
18.3	65	998.54	62.336
21.1	70	997.97	62.301
23.0	73.4	997.54	62.274
23.9	75	997.32	62.261
26.7	80	996.59	62.216
29.4	85	995.83	62.166



## PRACTICE QUESTIONS:

1. The one-point has to fall on the reference curve or within \_\_\_\_\_ of the curve at the one-point moisture content (according to AASHTO T272)?

- a.  $\pm 2.5 \text{ lb/ft}^3$
- b.  $\pm 3.5 \text{ lb/ft}^3$
- c.  $\pm 2.0 \text{ lb/ft}^3$

Go to  
section

2. How many Grams of Soil should be used for the average Calcium Carbide Moisture Tester (according to AASHTO T217)?

- a. 15 grams
- b. 20 grams
- c. 10 grams

Go to  
section

3. When performing T272 One-Point Proctor (method from T99) Method A or Method B is used if \_\_\_\_\_ or less of the material is retained on the \_\_\_\_\_ screen?

- a. 40%, #4
- b. 30%,  $\frac{3}{4}$ "
- c. 30%, #4

Go to  
section

4. AASHTO T191: When performing the procedure to determine the density of the soil as you dig out the hole and place the material into a container you must keep it covered to avoid losing moisture?'

- a. False
- b. True

Go to  
section

5. AASHTO T19 SECTION 8: What is the first step when calibrating a measure?

- a. Weigh the measure to the nearest 0.1lb or agency determined weight.
- b. Apply thin layer grease to rim (or rims) and weigh.
- c. Fill the measure with room temperature water.

Go to  
section

6. Oversized correction (ANNEX T99) is applied to samples that are more than \_\_\_\_\_ by weight of the sample.?

- a. 40%
- b. 10%
- c. 5%

Go to  
section

7. AASHTO T191: What do you weigh the sand cone apparatus to during the cone correction step?

- a. 0.01kg
- b. 0.01lb
- c. 0.01grams

Go to  
section

### ANSWERS:

- 1. c
- 2. b
- 3. a
- 4. b
- 5. b
- 6. c
- 7. b



## ***In Place Density Nuclear***

*In-place nuclear density testing is a sophisticated and widely used method in geotechnical engineering and construction for determining the density and moisture content of soil. The following procedures are precise and immediate and are important for assessing soil compaction which ensures the structural integrity of construction projects.*

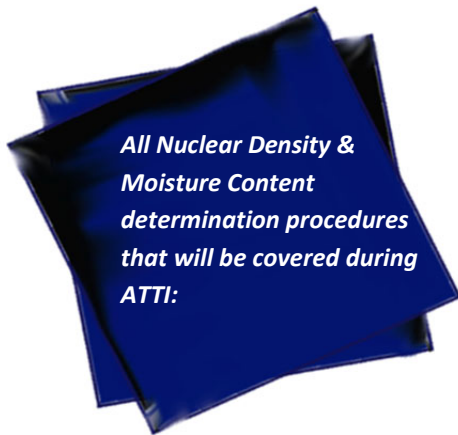

- **AASHTO T310:** *IN PLACE DENSITY AND MOISTURE CONTENT OF SOIL – AGGREGATE BY NUCLEAR METHODS*
- **AASHTO T355:** *DENSITY OF COMPACTED BITUMINOUS MIXTURES BY NUCLEAR METHOD*
- **AASHTO T265:** *MOISTURE CONTENT OF SOILS*
- **AASHTO T255:** *MOISTURE CONTENT OF AGGREGATES*

**Learning objectives for these sections are:**

- 🌱 ***How to perform and calculate in place nuclear density and moisture testing for soils using the direct transmission method.***
- 🌱 ***How to perform and calculate in place nuclear density testing for asphalt using the backscatter method.***
- 🌱 ***How to properly perform and calculate moisture content procedures for both soils and aggregates.***

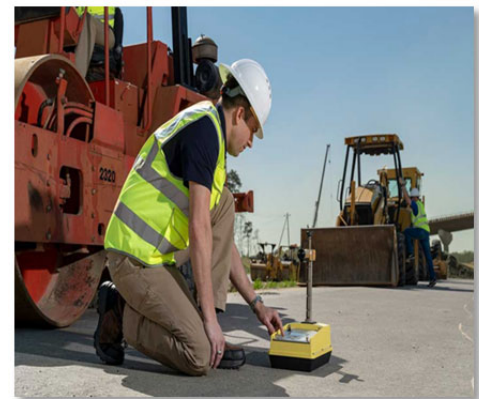

**PLEASE REFER TO THE SECTION FOUND IN THE PROCEDURE FOR MORE DETAIL. SECTIONS WILL BE INCLUDED FOR REFERENCE.**





# AASHTO T310:

## INPLACE – DENSITY AND MOISTURE CONTENT OF SOIL / AGGREGATE BY NUCLEAR METHODS

### SCOPE: 1.1.

**DEFINITIONS:**

**Percent Compaction** - it means that the compacted soil has reached a percentage of its maximum possible dry density as determined by a laboratory proctor test.

**Direct Transmission** – is when the sensor (located in the back of the gauge) measures the amount of gamma radiation given off by the source rod. The *less* radiation detected by the sensor the higher the material’s density.

*This method describes the procedure for determining the in-place density & moisture of soil and aggregate by the use of a nuclear gauge. For soils and aggregates we will utilize the direct transmission method.*

### EQUIPMENT: 5.

- **NUCLEAR DENSITY/ MOISTURE GAUGE (SEALED RADIATION SOURCE)** with instruction manual
- **TRANSPORT CASE**
- **GAMMA DETECTOR**
- **REFERENCE STANDARD / BLOCK** – a block of material used for checking gauge operations.
- **STRAIGHT EDGE / PLATE / LEVELING TOOL**
- **DRIVE PIN** – see instruction manual
- **SLIDE HAMMER** – see instruction manual
- **DRIVE PIN EXTRACTOR** – see instruction manual
- **RADIOACTIVE MATERIAL & CALIBRATION PACKET** – **CONTAINS:** daily standard count log, factory & laboratory calibration data sheet, Leak test cert, Procedure for handling, Shipper’s declaration for dangerous goods, anything else required by local agencies.

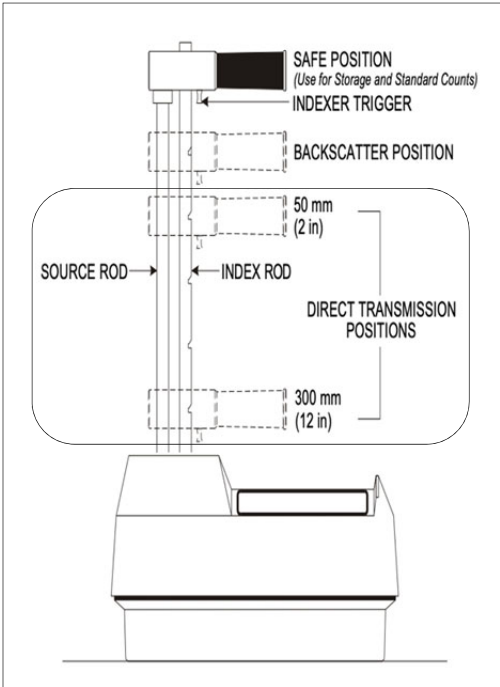

## STANDARDIZE

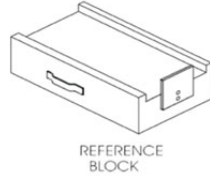

**When gauge is seated on the reference block make sure the gauge is butted up against the metal plate on the block.**

- **Standardization** of the gauge on the reference standard / block is required **every day** and a permanent record must be maintained. 8.2.
- Perform the standardization at least **30 feet** from any **other gauge** or other radioactive sources. Also, the gauge should be clear of any other large masses. *Close proximity to these may affect the reference count rates.* 8.2.
- Follow **manufacturer's manual** on how to turn on and **stabilize** the gauge. 8.2.1
- While on the standardization block take at least **four repetitive readings** and obtain the **mean (Average)**. *Note: Most gauges do this automatically.* 8.2.2
- If the **mean of the 4 repetitive readings** is **outside the limits** set by the procedure's equation **repeat** the standardization check. If the second check is still outside, refer to the annex from the procedure. 8.2.3

## PROCEDURE:

*The nuclear gauge used emits gamma rays into the soil, and the amount of radiation that is reflected back to the detector is used to determine the material's density. The moisture content is measured simultaneously allowing real time decisions about compaction quality.*

- 1** Place the gauge **at least 6" away** from any **vertical mass** to get an accurate reading. *If closer than 24 inches to a vertical mass follow the manufacturer's guide for the correction procedure.* 9.1.

- 2** Remove any loose debris to expose the area to be tested. 9.2.1

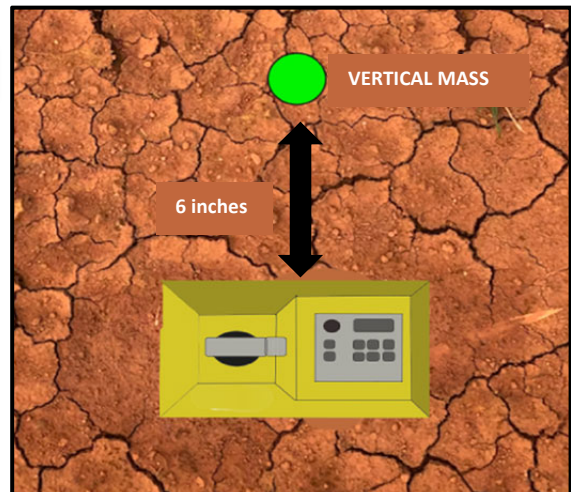

**3** Where the technician plans to test, **plane a horizontal area** to a smooth condition. Make sure the area is large enough to accommodate the gauge. 9.2.2.

**4** Turn on the gauge and allow to **stabilize**. Follow manufacturer's guidelines. 9.3.

**5** Create a **hole** into the prepared surface with the guide plate, drive pin, and hammer. Drive the pin at least **2 inches deeper** than the desired measurement. 9.5.2

**6** Mark around the **guide plate** to make it easier to place the gauge appropriately. 9.5.3.

**7** Remove the **pin** and guide plate from the area carefully so that the hole does not become distorted or any material falls in. 9.5.4.

**8** Place the gauge over the area making sure there is **maximum surface contact**. 9.5.5.

**9** Lower the source rod into the hole to the desired depth. Once lowered gently **pull back** on the gauge until the source rod **contacts the side** of the hole. 9.5.6.

**Do not exceed 1/8-inch voids beneath the gauge. If so, use native fines or fine sand to fill the voids and smooth the surface. The total area filled should not exceed 10% of the area of the bottom of the gauge.**

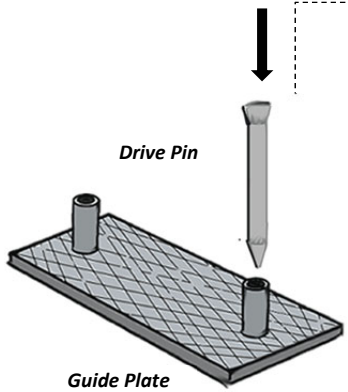

**10** Secure and record **one or more 1-minute readings**. All densities are recorded to **0.1 lb/ft<sup>3</sup>**. 9.5.9.

**11** Determine the in-place **Wet Density, Dry Density, Water Content, ...etc** directly from the gauge. 9.5.10.

**12** When taking a representative sample for **moisture content / density determination** remove from directly underneath the gauge. Remove the approximate depth the rod was lowered. **This is where you receive the material for your rock correction.** 9.6.

**i** *If needed the gauge can be rotated about the axis of the source rod to obtain more readings.*



**CALCULATION PERCENT COMPACTION:**

$$\% \text{ Compaction} = \frac{\text{In Place Dry Density}}{\text{Maximum Dry Density}} \times 100$$

*\*Normally this will be displayed on the gauge directly.*

**EXAMPLE OF PRINT OUT FROM A TROXLER DENSITY GAUGE.**

```

*****
PROJECT NUMBER: 1
SN: 59441 DATE: 3/16/2000
*****
STA # 1      2:30 PM  3/16/2000
DEPTH: 4 inches
TIME: 15 seconds UNITS: PCF
Std Cnts: D 3445 M 26
Dens Cnt. 3568 Moist Cnt. 32
WD = -      DD = -
PR = 145.0%PR = -
M = +      %M = +++++
Optional Data:
1234567890.1

```

```

-----
STA # 2      2:30 PM  3/16/2000
DEPTH: 6 inches
TIME: 15 seconds UNITS: PCF
Std Cnts: D 3445 M 26
Dens Cnt. 3559 Moist Cnt. 27
WD = -      DD = -
PR = 145.0%PR = -
M = +      %M = +++++

```

**REPORT:**

*Standardization and adjustment data for the date of the tests;*

*Make, Model, and serial number of the Nuke Gauge;*

*Name of the technician;*

*Test Site Identification;*

*Visual description of material;*

*Test Mode;*

*Wet Density;*

*Dry Density;*

*% Compaction;*

*Water Content in % of Dry Mass;*

*Any adjustments mad to the reported values;*

# AASHTO T355:

## DENSITY OF COMPACTED BITUMINOUS MIXTURES BY NUCLEAR METHOD

**DEFINITIONS:**

**Back Scatter Mode** – when in back scatter mode the source is in the same plane as the sensor. The shielding within the gauge means that radiation given off the source must first be deflected by the material before reaching the sensor. The *more* radiation detected by the sensor the higher the material’s density.

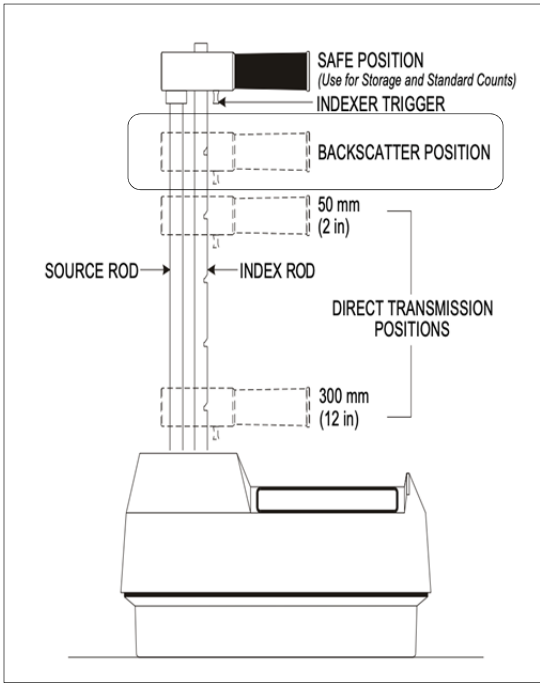

**SCOPE:** 1.1.

*This method describes the procedure for determining the in-place density of ASPHALT MIXTURES by use of the nuclear gauge.*

**EQUIPMENT:** 5.

- **NUCLEAR DENSITY/ MOISTURE GAUGE (SEALED RADIATION SOURCE) with instruction manual**
- **TRANSPORT CASE**
- **GAMMA DETECTOR**
- **REFERENCE STANDARD / BLOCK** – a block of material used for checking gauge operations.
- **STRAIGHT EDGE / PLATE / LEVELING TOOL**
- **FILLER MATERIAL-** fine graded sand made of acceptable material.
- **RADIOACTIVE MATERIAL & CALIBRATION PACKET** – **CONTAINS:** daily standard count log, factory & laboratory calibration data sheet, Leak test cert, Procedure for handling, Shipper’s declaration for dangerous goods, anything else required by local agencies.

## STANDARDIZE:

- **Standardization** of the gauge on the reference standard / block is required **every day** and a permanent record must be maintained.
- Perform the standardization at least **30 feet** from any **other gauge** or other radioactive sources and **10 feet** away from **large masses**.
- Follow **instruction manual** on how to turn on and **stabilize** the gauge.
- While on the standardization block take at least **four repetitive readings** and obtain the **mean**. *Note: Some gauges will do this automatically.*
- If the **mean of the 4 repetitive readings** is outside the limits set by the procedure's equation repeat the standardization check. If the second check is still outside, refer to the **annex** from the procedure.

8.2.

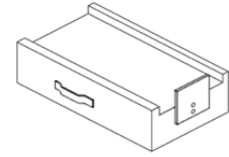

REFERENCE  
BLOCK

8.2.

**When gauge is seated on the reference block make sure the gauge is butted up against the plate on the block.**

8.2.1.

8.2.2.

8.2.3.

**Take the standard counts in the same environment as the actual measurement counts.**

## PROCEDURE:

*The nuclear density gauge works by using a small source of gamma radiation (usually Cesium-137 or Americium-241) to send gamma rays into the compacted asphalt mixture. When the gamma rays interact with the material, some of the rays are scattered back to the detector, while others are absorbed by the material. The density of the material is then determined by the backscatter/air gap ratio method. See the procedure for more details.*

### Alternate Method 1 – 90 Degree Rotation

1

Select a relatively **flat test location**. Make sure the gauge is at least **10 feet away** from any **large object**. *If closer than 24 inches to a vertical mass or less than 12 inches from a vertical pavement edge follow the manufacturer's guide for the correction procedure.*

9.1.

**2** The gauge must maintain **full contact** between its base and the **surface** of material. If there are surface **voids** use filler material to **fill them in**. Spread a small amount of filler over the voids and distribute evenly. Strike off with a straight edge to remove excess material. 9.2.1.

**3** Place the gauge on the test site **perpendicular** to the **direction of travel of the rollers**. Mark the **outline** of the foot print of the **gauge**. 9.3.1.1.

**4** Place the gauge in the **back scatter** position. 9.3.1.1.

**5** Take a **1-minute test** and record the **wet density** reading. Record to **0.1 lb/ft<sup>3</sup>**. 9.3.1.2.

**6** Rotate the gauge **90 degrees** centered over the original outline. Mark the outline of the new position. 9.3.1.3.

**7** Take a **1-minute test** and record the **new wet density** reading. 9.3.1.4.

**8** If the **difference** between the **2 readings** is **greater than 2.5 lb/ft<sup>3</sup>** then **retest** in **BOTH directions**. 9.3.1.6.

**9** If the difference between the retests is still higher then **repeat the test at 180° & 270°**. 9.3.1.6.

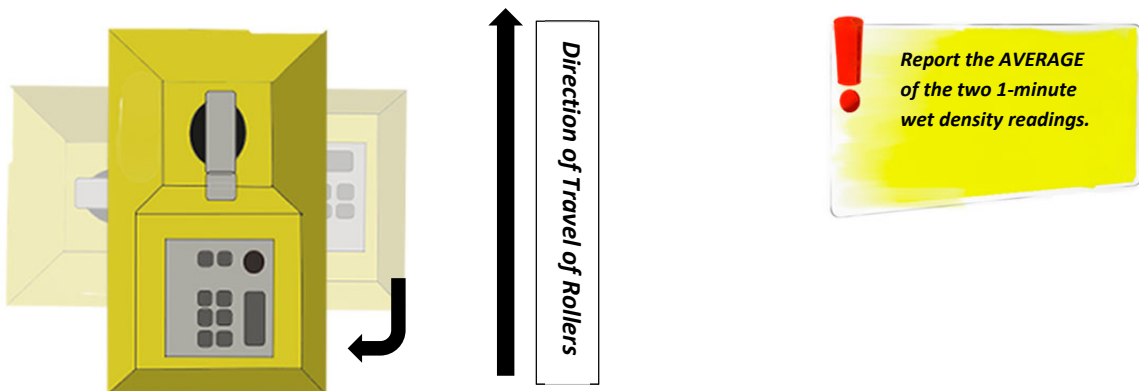

## Alternate Method 2 – 180 Degree Rotation

- 1** Prepare your test area the same as **SECTION 9.1.2**.
- 2** Place the gauge on the test site **parallel** to the **direction of travel of the rollers**. Mark the outline of the foot print of the gauge. 9.3.2.1.
- 3** Take a **1-minute reading** & record the **wet density**. **Record all densities to 0.1 lb/ft<sup>3</sup>**. 9.3.2.2.
- 4** **Rotate** the gauge **180 degrees** centered over the original outline. 9.3.2.3.
- 5** Take another **1-minute reading** & record the **wet density**. 9.3.2.4.
- 6** If the **difference** between the **2 readings** is **greater** than **2.5 lb/ft<sup>3</sup>** then retest in **BOTH** directions. 9.3.2.5.

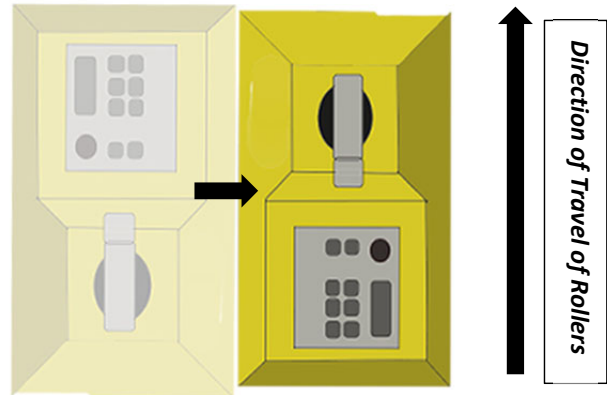
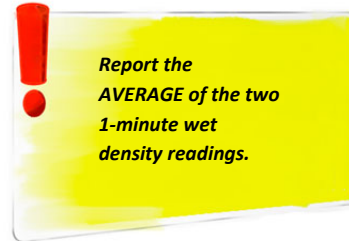

## Alternate Method 3

- 1** Place the **gauge** on the test site **parallel** to the direction of travel of the rollers. **Mark the outline** of the foot print of the gauge. 9.3.3.1.
- 2** Take a **4-minute test** and record the **wet density**. **Record all densities to 0.1 lb/ft<sup>3</sup>**. 9.3.3.2.





**REPORT:**

*Standardization and adjustment data for the date of the tests;*

*Make, Model, and serial number of the Nuke Gauge;*

*Name of the technician;*

*Date of last calibration / verification;*

*Test Site Identification;*

*Thickness of layer tested;*

*Density;*

*% Compaction (Corrected with Cores if Applicable);*

**AASHTO T265:  
STANDARD METHOD OF TEST  
FOR LABORATORY  
DETERMINATION OF  
MOISTURE CONTENT OF SOILS**

**SCOPE:**

1.1.

*This method covers the procedure for determining the moisture content of soils.*

**EQUIPMENT:**

4.

- **DRYING OVEN** – Thermostatically controlled capable of being heated continuously at a temperature of  $230 \pm 9^\circ\text{F}$
- **BALANCE** – Readable to at least 0.1 % of the sample mass.
- **CONTAINERS** – Made of material resistant to corrosion and not subject to change in mass by repeated heating and cooling. Shall have close-fitting lid to prevent loss of moisture.



**SAMPLE:**

- Test sample quantity is generally indicated in the test method. If it is not, then find the minimum mass from the table in the procedure. Seen here:

5.1.

Maximum Particle Size	Minimum Mass of Sample, g
0.425-mm (No. 40) sieve	10
4.75-mm (No. 4) sieve	100
12.5-mm ( $\frac{1}{2}$ in.)	300
25.0-mm (1 in.)	500
50-mm (2 in.)	1000

**PROCEDURE:**

**1** Weigh a clean, dry container with its lid and record this weight. Record the weight to 0.1% of the mass of the sample.

6.1.

**2** Place the moisture content sample in the container and place the lid immediately on and weigh. Record this weight.

6.1.

**3** When ready to put in the oven remove the lid and place the container with the sample in the oven at 230 ± 9°F at a minimum of 15 hrs or dry until the sample mass loses no more than 0.1% after 1 hour of additional drying.

6.1.

**4** After removing from the oven place the lid on the sample and allow to cool to room temperature.

6.1.

**5** Weigh the container including the lid and the dried sample. Record the weight to 0.1% of the mass of the sample.

6.1.

**!** Dried samples cannot be placed in the same oven as wet samples.

**?** CAN A CONTAINER WITHOUT A LID BE USED?  
It can be used if the sample is weighed immediately after being taken and weighed immediately after being removed from the oven.

**CALCULATION OF MOISTURE CONTENT**

$$W = \left[ \frac{(W1 - W2)}{(W2 - Wc)} \right] \times 100$$

**W = Moisture content in percent.**

**W1** = Mass of the container and sample in grams.

**W2** = Mass of the container and oven-dried sample in grams.

**Wc** = Mass of the container in grams.

**AASHTO T255:  
STANDARD METHOD OF TEST  
FOR TOTAL EVAPORABLE  
MOISTURE CONTENT OF  
AGGREGATE BY DRYING.**

**SCOPE:**

1.1.

*This test method covers the determination of the percentage of evaporable moisture in a sample of aggregate by drying both surface moisture and moisture in the pores of the aggregate.*

**EQUIPMENT:**

5.

- **SOURCE OF HEAT** – Thermostatically controlled AND ventilated oven capable of being heated continuously at a temperature of  $230 \pm 9^{\circ}\text{F}$ . Other sources of heat can be used such as a hot plate, electric heat lamps and a ventilated microwave oven.
- **BALANCE** – Readable to at least 0.1 % of the sample mass.
- **CONTAINERS** – Made of material resistant to corrosion and not subject to change in mass by repeated heating and cooling. Volume enough to contain the sample without spilling and where the sample depth that will not exceed one-fifth of the least lateral dimension.
- **STIRRER**

**SAMPLE:**

- For sampling utilize **R90 & the sample shall conform to Table 1** in the procedure.

6.1.

Nominal Maximum Size of Aggregate, mm (in.) <sup>a</sup>	Mass of Normal Weight Aggregate Sample, Min., kg <sup>b</sup>
4.75 (0.187) (No. 4)	0.5
9.5 (3/8)	1.5
12.5 (1/2)	2
19.0 (3/4)	3
25.0 (1)	4
37.5 (1 1/2)	6
50 (2)	8
63 (2 1/2)	10
75 (3)	13
90 (3 1/2)	16
100 (4)	25
150 (6)	50

<sup>a</sup> Based on sieves meeting ASTM E11.

<sup>b</sup> Determine the minimum sample mass for lightweight aggregate by multiplying the value listed by the dry-loose unit mass of the aggregate in kg/m<sup>3</sup> (determined using T 19M/T 19) and dividing by 1600.

- Obtain the representative aggregate sample having a mass that is **at least minimum amount** that is outlined in the table.

6.1.

- Protect** the sample from a **loss of moisture** before determining the mass of the sample.

6.2.

### PROCEDURE:

1

Determine the **mass** of the sample to the nearest **0.1%**.

7.1.

2

**Dry** the sample in the sample container by means of the selected **source of heating**. Avoid loss of particles.

7.2.

**Rapid heating may make particles explode losing material. Use controlled heating. If not possible then stir constantly to avoid over localized heating.**

- 3** Once dried determine the mass of the dried sample to the **nearest 0.1%** after it has cooled to the point where it won't damage the balance.

7.4.



*Sample is dry when further heating causes less than 0.1% additional loss in mass.*

**TOTAL EVAPORABLE MOISTURE CONTENT CALCULATION**

$$P = \frac{100*(W-D)}{D}$$

**P** = total evaporable moisture content of sample (percent);

**W** = mass of original sample (grams);

**D** = mass of dried sample (grams)



**WHAT IS THE SURFACE MOISTURE CONTENT?**

*It's the difference between the total evaporable moisture content result and the absorption. All values are based on the mass of a dry sample. Absorption can be determined by T85 or T84*



## PRACTICE QUESTIONS:

1. When performing AASHTO T255 what does the technician determine the mass of the dried sample to?

- a. 0.01%
- b. 0.001%
- c. 0.1%

*Go to  
section*

2. When performing AASHTO T265 weigh a clean, dry container WITHOUT its lid and record this weight.

- a. True
- b. False

*Go to  
section*

3. When determining in place density of asphalt mixtures according to AASHTO T355 take a \_\_\_\_ test and record the new wet density reading.

- a. 1 Minute
- b. 10 Seconds
- c. 5 Minutes

*Go to  
section*

4. When standardizing a nuclear gauge how far does another gauge (or other radioactive source) have to be?

- a. 10 feet
- b. 20 feet
- c. 30 feet

*Go to  
section*

5. When standardizing a nuclear gauge while on the reference block take at least \_\_\_\_ repetitive readings and obtain the mean.

- a. 3
- b. 4
- c. 2

*Go to  
section*

ANSWERS:

- 1. c
- 2. b
- 3. a
- 4. c
- 5. b

